

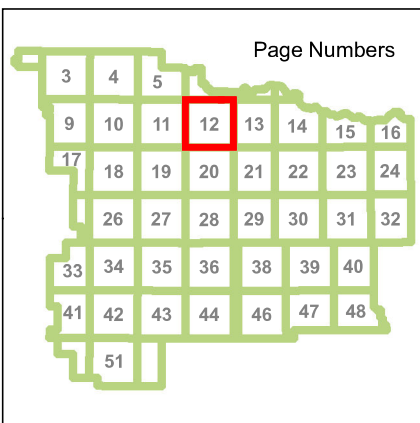

Foothills County
Land Use Map Book

Subject Parcel

21-01

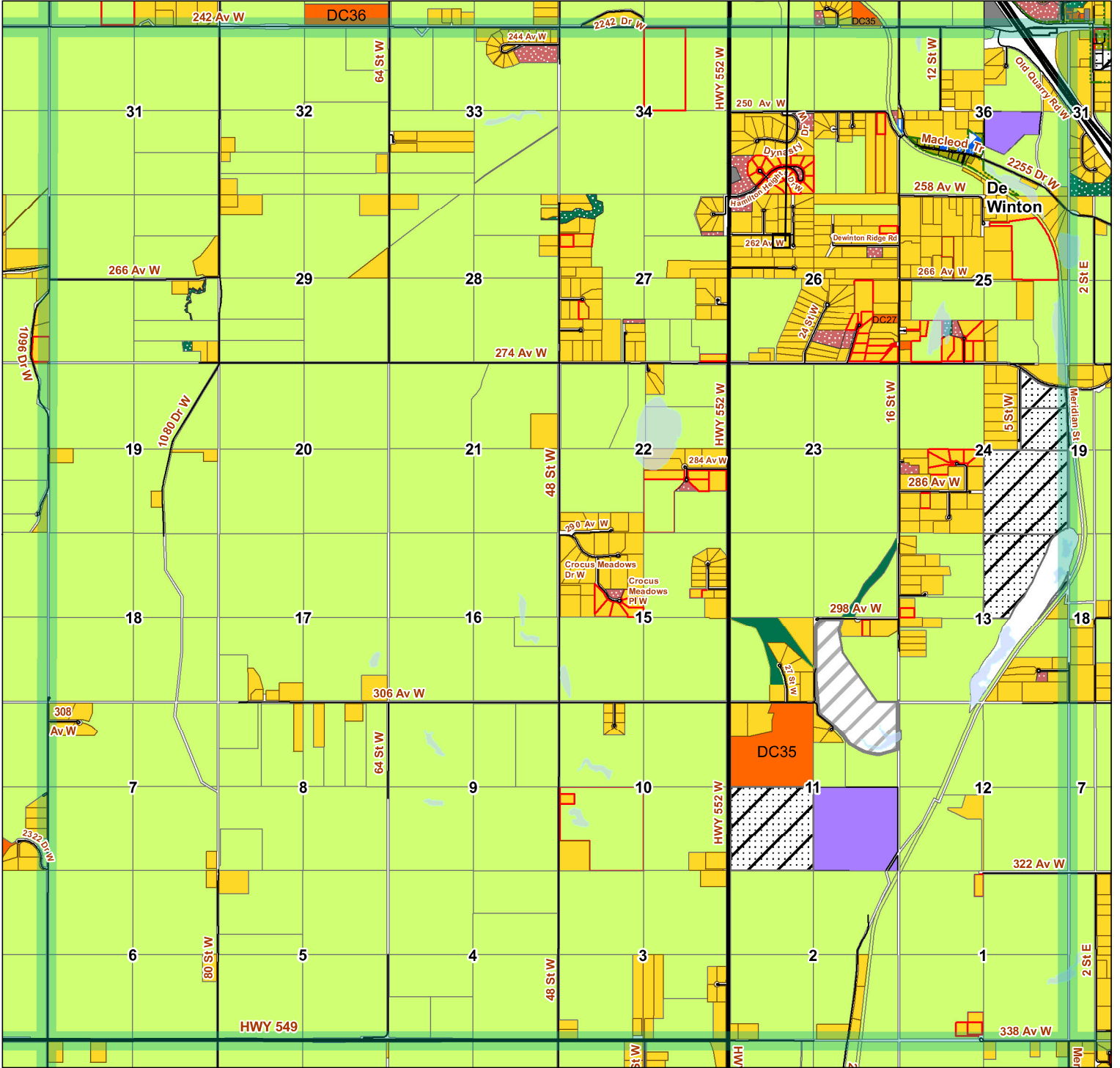

Legend

- County Roads
- Highways
- ⋯ In Transition
- NA - Not Applicable
- A- Agricultural
- AA- Agricultural Sub A
- CMC- Community Commercial
- CR- Country Residential
- CRA- Country Residential Sub A
- DC - Direct Control
- ER- Environmental Reserve
- EP- Environmental Protection
- INR- Natural Resource Extraction
- MR- Municipal Reserve
- REC- Recreation
- PUL- Public Utility
- RC- Residential Community District
- RMFA- Residential Multi Family Subdistrict A
- SD- Service District

This map is compiled by the Foothills County. Reproduction, in whole or in part, is prohibited without express permission from the Foothills County. Foothills County provides this information in good faith, but provides no warranty, nor accepts any liability arising from incorrect, incomplete or misleading information, or its improper use.

Data Sources Include Municipal Records and AltALIS.
© Foothills County 2026

February 28, 2026



Page 12

PART 3 SITE INFORMATION

Area Of Lot: (In Acres Or Hectares) 4.36 Acres

Size Of Proposed Building: 35.42M Height: 3.65M

Is There A Dwelling (Residence) On The Site: Yes yes No If Yes, How Many? 1

Utilities Presently On Site: electric, gas, water, telecommunication, internet

Are There Sour Gas Or High Pressure Facilities On Site? No

Utilities Proposed: electirical

Other Land Involved In Application:

DISCLAIMER: Please note that the personal information collected on this form is authorized under the Municipal Government Act and is required for the purpose of the County's Planning and Development processes. This information may also be shared with appropriate government agencies and may also be kept on file by those agencies. The application and related file contents will become available to the public and are subject to the provisions of the Freedom of Information and Protection of Privacy Act (FOIP). if you have any questions about the collection and use of this information, please contact the FOIP Coordinator at 403-652-2341.

PART 4 DEVELOPMENT

Specify other supporting material attached that forms part of this application. (e.g., Site Plan, Plot Plan, Architectural Drawings, etc.):

Site Plan, Single Line Diagram, Material Specs Sheets

Estimated Date of Commencement: March/2026 Estimated Date of Completion: March/2026

I, Cam Perdonic of Nuvo Renewable

hereby certify that I am:

- The Registered Owner; or
- Authorized to act on behalf of the Registered Owner

Date: 2026-02-12

RIGHT OF ENTRY

I, being the owner or person in possession of the above described land and any building thereon, hereby consent to an authorized person designated by Foothills County to enter upon the land for the purpose of inspection during the processing of this application.

2026-02-12
Date



Signature of Owner or Authorized Agent

FOR OFFICE USE ONLY

- 1. Land use district: Country Residential
- 2. Listed as a permitted/discretionary use: Discretionary
- 3. Meets setbacks: Yes No If "NO", deficient in _____

- 4. Other information: _____

PART 5 DECISION

Date of Decision: May 6, 2026 Date Application Accepted: _____

This Development Permit Application is:

- APPROVED
- APPROVED subject to the attached conditions
- REFUSED for the attached reasons

Notice of Decision Advertised: May 6 & 13, 2026

Date of Issuance of Development Permit: _____

Development Officer

NOTE: Development must commence within 12 months of the date of the Date of Issuance of the Permit and be completed within 24 months of the Date of Issuance, unless otherwise stated in the Development Officer's decision.

ENCUMBRANCES, LIENS & INTERESTS

PAGE 2
131 277 407

REGISTRATION

NUMBER DATE (D/M/Y) PARTICULARS

011 018 806 18/01/2001 CAVEAT
RE : DEVELOPMENT AGREEMENT PURSUANT TO MUNICIPAL
GOVERNMENT ACT
CAVEATOR - THE MUNICIPAL DISTRICT OF FOOTHILLS NO.
31.
BOX 5605
HIGH RIVER
ALBERTA T1V1M7

011 018 834 18/01/2001 RESTRICTIVE COVENANT

TOTAL INSTRUMENTS: 003

THE REGISTRAR OF TITLES CERTIFIES THIS TO BE AN
ACCURATE REPRODUCTION OF THE CERTIFICATE OF
TITLE REPRESENTED HEREIN THIS 5 DAY OF MARCH,
2026 AT 08:13 A.M.

ORDER NUMBER: 56466541

CUSTOMER FILE NUMBER: AS_Planning

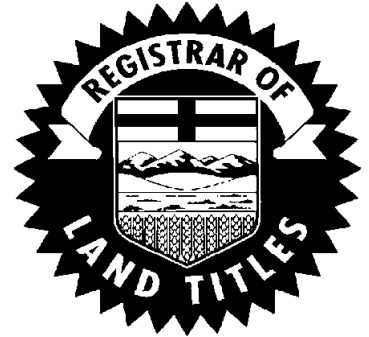

END OF CERTIFICATE

THIS ELECTRONICALLY TRANSMITTED LAND TITLES PRODUCT IS INTENDED
FOR THE SOLE USE OF THE ORIGINAL PURCHASER, AND NONE OTHER,
SUBJECT TO WHAT IS SET OUT IN THE PARAGRAPH BELOW.

THE ABOVE PROVISIONS DO NOT PROHIBIT THE ORIGINAL PURCHASER FROM
INCLUDING THIS UNMODIFIED PRODUCT IN ANY REPORT, OPINION,
APPRAISAL OR OTHER ADVICE PREPARED BY THE ORIGINAL PURCHASER AS
PART OF THE ORIGINAL PURCHASER APPLYING PROFESSIONAL, CONSULTING
OR TECHNICAL EXPERTISE FOR THE BENEFIT OF CLIENT(S).

Brittany Smith

From: FC_Planning
Sent: March 4, 2026 3:51 PM
To: projectmanagersouthernalberta@sjrb.ca; [REDACTED]
Cc: Brittany Smith
Subject: Notice of Complete Application – Development Permit 26D 074

Good Afternoon ,

**Re: Notice of Complete Application – Development Permit 26D 074
Ptn: NW 26-21-1 W5M; Plan 0110200, Block 3, Lot 7
Solar Power System, Private**

Section 683.1 of the Municipal Government Act requires the Development Authority, within 20 days after the receipt of an application for a development permit, to determine whether the application is complete or incomplete. This letter is being sent to you to serve as a notice of acknowledgement that the application as noted above is considered **complete** as of March 4, 2026.

Please note, this is not an approval of your permit, but indicates that your application has been accepted by the County and will now proceed to the next stages of the development permit process.

Notwithstanding the above, in the course of processing your application, we may request additional information or documentation from you that is considered necessary to review your application.

If you have any questions or concerns regarding the information in this letter, please contact **Brittany Smith** at Brittany.Smith@foothillscountyab.ca .

Regards,

**Foothills County
Planning & Development**

FC_Planning@foothillscountyab.ca

Foothills County, 309 Macleod Trail S. /Box 5605, High River, AB T1V 1M7

P. (403) 652-2341 | F. (403) 652-7880



W. www.foothillscountyab.ca



Client Name	: Catherine Bye	Module Type	: LR7-72HTH-615M
Address	: Plan 0170200, Block 3, Lot 7 (NW 26 21 1 W5) De Winton AB	No. of Modules	: 60
Site ID	: 0040000539156		
Inverter	: APS DS3		

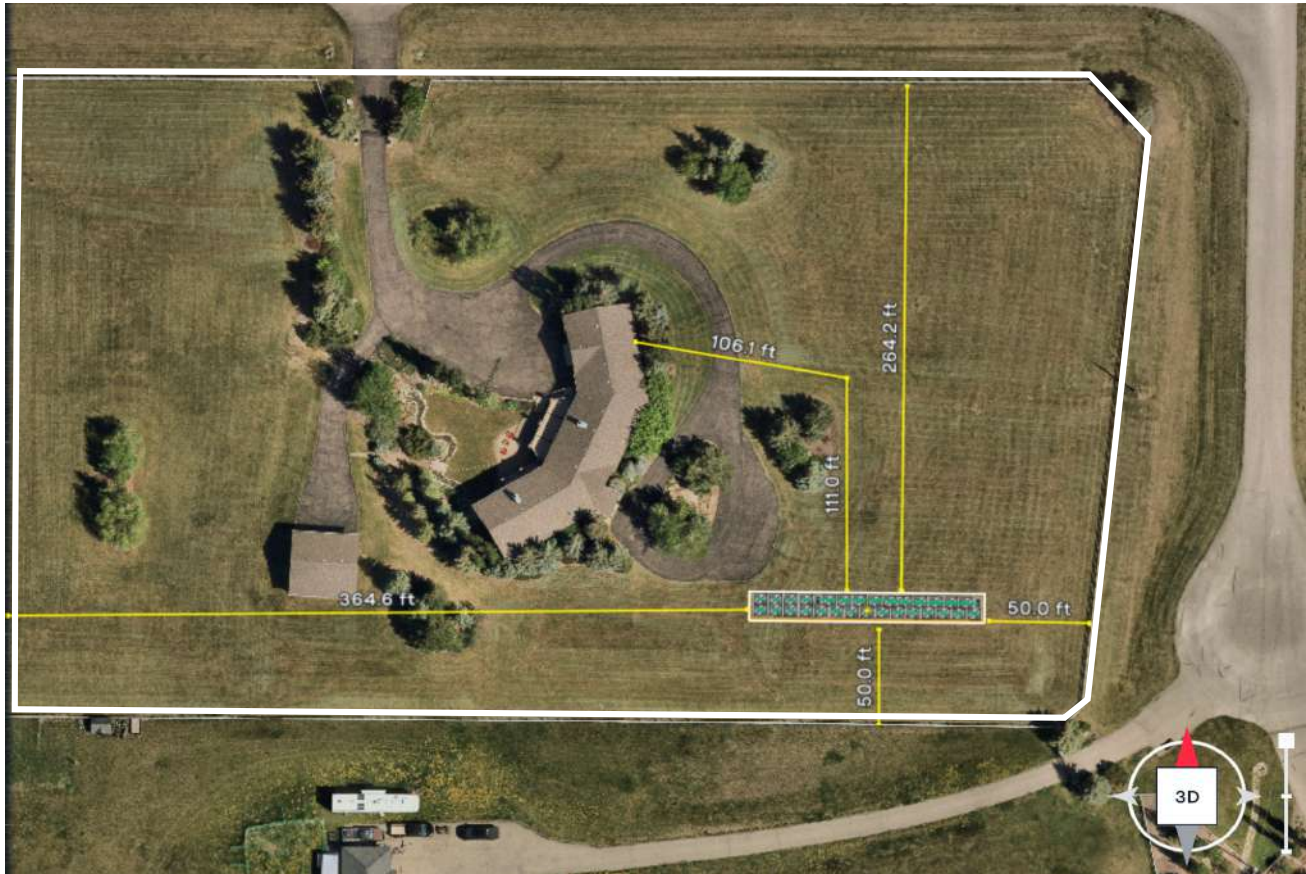



Solar Information Form	
Client Name	Catherine Bye
Client Address	Plan 0170200, Block 3, Lot 7 (NW 26 21 1 W5) De Winton AB TOL OXO
Site ID	0040000539156
PV System Capacity (DC) [kW]	36.90
PV System Capacity (AC) [kW]	26.40
Module Manufacturer & Type	Longi 615W
Module Model Number	LR7-72HTH-615M
Module Power Rating	615
Total Number of Modules	60
Module Warranty	25 years
Inverter Manufacturer	APSystems
No. of Modules (House)	60
No of Modules (Detached Garage)	N/A
Inverter Model	APS DS3
Number of Inverters	30
Array / Orientation #1	
Number of Modules in Array	60
Array Area (ft ²)	1744.8
Tilt/Slope (Degrees)	45.00
Azimuth (Degrees)	180 S



Client Name	: Catherine Bye	Module Type	: LR7-72HTH-615M
Address	: Plan 0170200, Block 3, Lot 7 (NW 26 21 1 W5) De Winton AB	No. of Modules	: 60
Site ID	: 0040000539156		
Inverter	: APS DS3		





Client Name : Catherine Bye
Address : Plan 0170200, Block 3, Lot 7 (NW 26 21 1 W5) De Winton AB
Site ID : TOL 0X0
Inverter : 0040000539156
Module Type : LR7-72HTH-615M
No. of Modules : 60

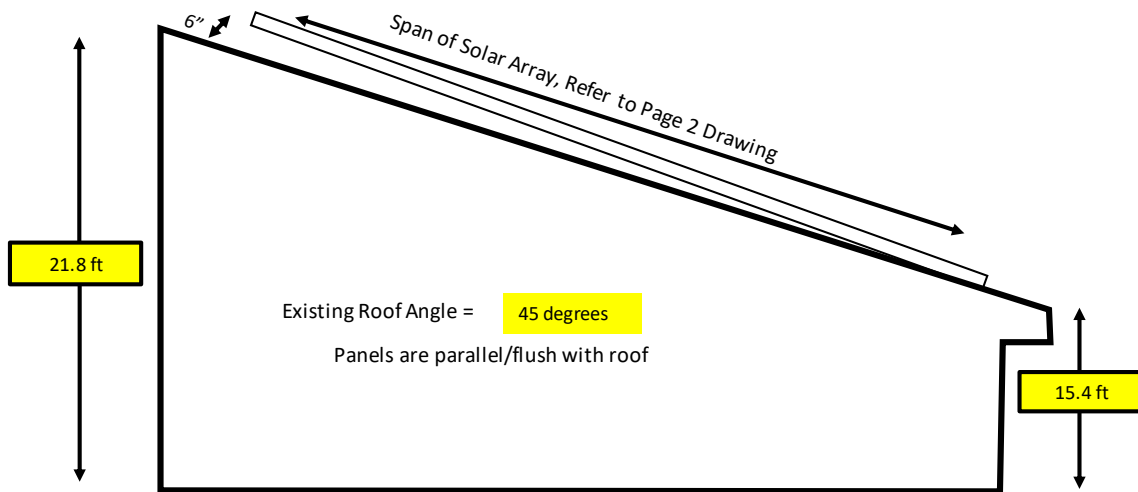

- All solar panels do not exceed maximum roof elevation (roof peak)
- Panels sit approximately 4-6" above roof surface

TYPICAL SOLAR PV MODULES
CONNECTED TO MICROINVERTERS

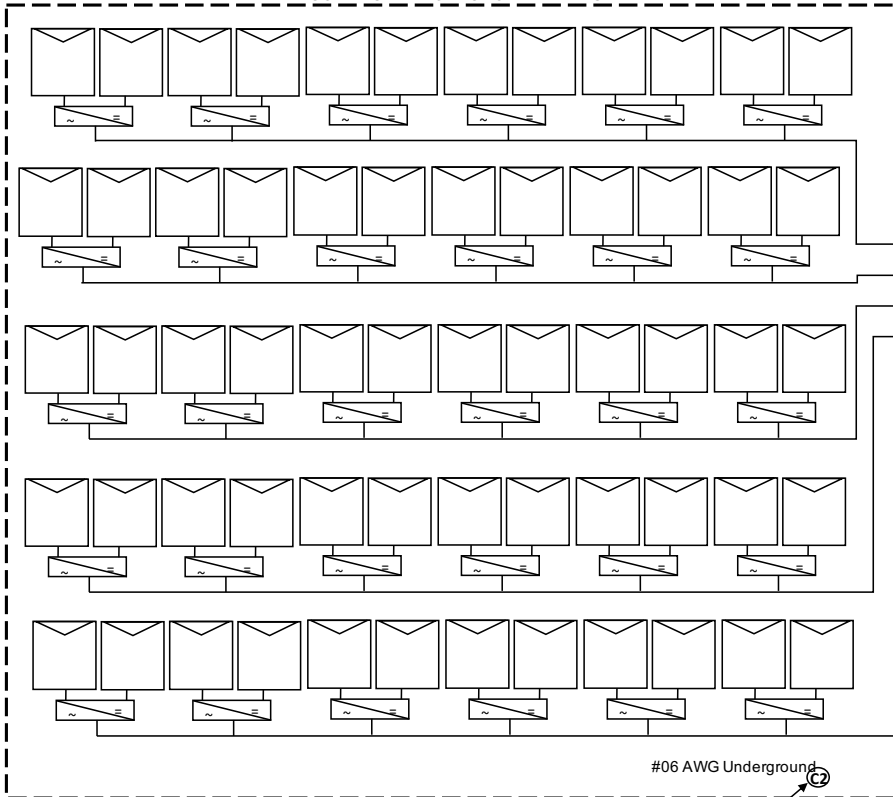

Load Centre:

- 240V Inverter output feeds Main Service Panel
- GEC is continuous from roof-top equipment to this point

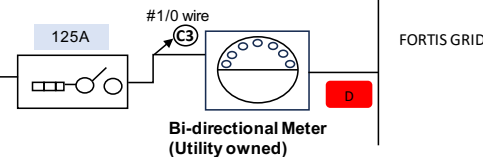

- to be installed after final inspection
- to be determined by Utility

Transformer to Main Panel - 250kcmil AL, 80m, 1.63V
Main Panel to Subpanel- 250kcmil AL, 67m, 1.37V
Inverter Feed - #10 CU, 3m, 1.06V

Voltage Rise - 4.06V
New Voltage - 250.06V
Percent Rise - 1.65%
FAB - 106%
Total Voltage Rise - 107.65%

DRAWING NOT TO SCALE	REVISION 0
Solar Photovoltaic Electrical Single Line Diagram	
Master Electrician	Date Drawn
Andrew Roebuck. -14114	2026-02-24
Client Information	
Site Name :	Catherine Bye
Site ID :	0040000539156
Site Address :	Plan 0170200, Block 3, Lot 7 (NW 26 21 1 W5) De Winton AB T0L 0X0
	
2875 107 Ave SE Calgary AB T2Z 4S8 nuvorenewables.com hello@nuvorenewables.com	

No. of Modules	Module Wattage	DC Size
60	x 615	= 36.9kW
No. of Inverters	Max Output Power	AC Size
30	x 880 VA	= 26.40kW
EQUIPMENT SPECIFICATIONS		
Modules :	Longi 615W	Inverter :
	LR7-72HTH-615M	APS DS3
	(at STC)	
Pmp :	615	One microinverter connects to two solar modules, Two independent input channels (MPPT), CA Rule 21 (UL 1741 SB) Compliant, NEC 2020 690.12 Rapid Shutdown Compliant, 240V AC Output, Encrypted Wireless Zigbee Communication, Phase Monitored and Phase Balanced
Voc :	52.57	
Isc :	14.87	
Vmp :	44.33	
Imp :	13.88	
Solar Racking :		Clenergy PVEzRack SolarTerrace III-A
Mounting Hardware, integrated WEEB bonding connections ensure continuous bond of all equipment to rails.		

- A** 1 x WARNING:
TWO POWER SOURCE PARALLEL SYSTEM
MAX AC OPERATING VOLTAGE &
MAX AC OPERATING CURRENT
- C**
- B** Per Breakers
1 x WARNING:
INVERTER CONNECTION
DO NOT RELOCATE OVERCURRENT DEVICE
- D** Meter
1 x WARNING:
TWO POWER SOURCE PARALLEL SYSTEM

- Note 1** Line side Tap installed in accordance with rule 64-112) 2) of the CEC
- Note 2** NEMA 3R Main Lug Center. Solar Loads Only

This authorizes the application of the Certification Mark(s) shown below to the models described in the Product(s) Covered section when made in accordance with the conditions set forth in the Certification Agreement and Listing Report. This authorization also applies to multiple listee model(s) identified on the correlation page of the Listing Report.

This document is the property of Intertek Testing Services and is not transferable. The certification mark(s) may be applied only at the location of the Party Authorized To Apply Mark.

Applicant:	Clenergy Technology Co., Ltd	Manufacturer:	Clenergy Technology Co., Ltd
Address:	1001,1003,1005,1007,1009,Minan,Rd,Torch,High-tech,Ind.Dev.Zone,Xiangan District, Xiamen, Fujian 361101	Address:	1001,1003,1005,1007,1009,Minan,Rd,Torch,High-tech,Ind.Dev.Zone,Xiangan District, Xiamen, Fujian 361101
Country:	China	Country:	China
Party Authorized To Apply Mark:	Same as Manufacturer		
Report Issuing Office:	Intertek Testing Services Shanghai Limited		
Control Number:	<u>4005834</u>	Authorized by:	 for L. Matthew Snyder, Certification Manager



This document supersedes all previous Authorizations to Mark for the noted Report Number.

This Authorization to Mark is for the exclusive use of Intertek's Client and is provided pursuant to the Certification agreement between Intertek and its Client. Intertek's responsibility and liability are limited to the terms and conditions of the agreement. Intertek assumes no liability to any party, other than to the Client in accordance with the agreement, for any loss, expense or damage occasioned by the use of this Authorization to Mark. Only the Client is authorized to permit copying or distribution of this Authorization to Mark and then only in its entirety. Use of Intertek's Certification mark is restricted to the conditions laid out in the agreement and in this Authorization to Mark. Any further use of the Intertek name for the sale or advertisement of the tested material, product or service must first be approved in writing by Intertek. Initial Factory Assessments and Follow up Services are for the purpose of assuring appropriate usage of the Certification mark in accordance with the agreement, they are not for the purposes of production quality control and do not relieve the Client of their obligations in this respect.

Intertek Testing Services NA Inc.
545 East Algonquin Road, Arlington Heights, IL 60005
Telephone 800-345-3851 or 847-439-5667 Fax 312-283-1672

Standard(s):	Mounting Systems, Mounting Devices, Clamping/Retention Devices, and Ground Lugs for Use with Flat-Plate Photovoltaic Modules and Panels [UL 2703:2015 Ed.1+R:24Mar2021] PV Module and Panel Racking Mounting System and Accessories [CSA TIL No. A-40:2020]
Product:	Mounting Systems for Use with Flat-Plate Photovoltaic Modules and Panels
Brand Name:	CLENERGY, PV-ezRACK, SOLARROOF
Models:	SolarRoof with L feet, SolarRoof with ezClick L feet, SolarRoof with Tilt Legs, SolarRoof with Roof Hook, SolarRoof Tripod Light



DS3 Series

The most powerful Dual Microinverter

- One microinverter connects to two solar modules
- Max output power reaching 640VA, 768VA or 880VA
- Two independent input channels (MPPT)
- CA Rule 21 (UL 1741 SB) compliant
- NEC 2020 690.12 Rapid Shutdown Compliant
- Encrypted Wireless ZigBee Communication
- Phase Monitored and Phase Balanced

PRODUCT FEATURES

APsystems' 3rd generation of dual-module microinverters, the DS3 product family represents the culmination of years of power conversion expertise and innovation in high-efficiency, high-density power conversion to maximize the peak performance of today's high-capacity PV modules.

The DS3 series reaches unprecedented levels of power output. It features 2 input channels, each with independent MPPT, and encrypted wireless ZigBee communication. An innovative and compact design makes the product lighter while maximizing power production, and silicone-encapsulated components reduce stress on electronics, facilitate thermal dissipation, and enhance weatherproofing. Reliability is significantly increased thanks to 20% fewer components than previous generations. A 24/7 energy access through apps or web based portal facilitate remote diagnosis and maintenance.

The DS3 series is grid-interactive and fully compliant with CA Rule 21 requirements. With an excellent performance and high conversion efficiency, a unique integration with less components, the APsystems DS3 series is a gamechanger for residential and commercial solar.

WIRING SCHEMATIC

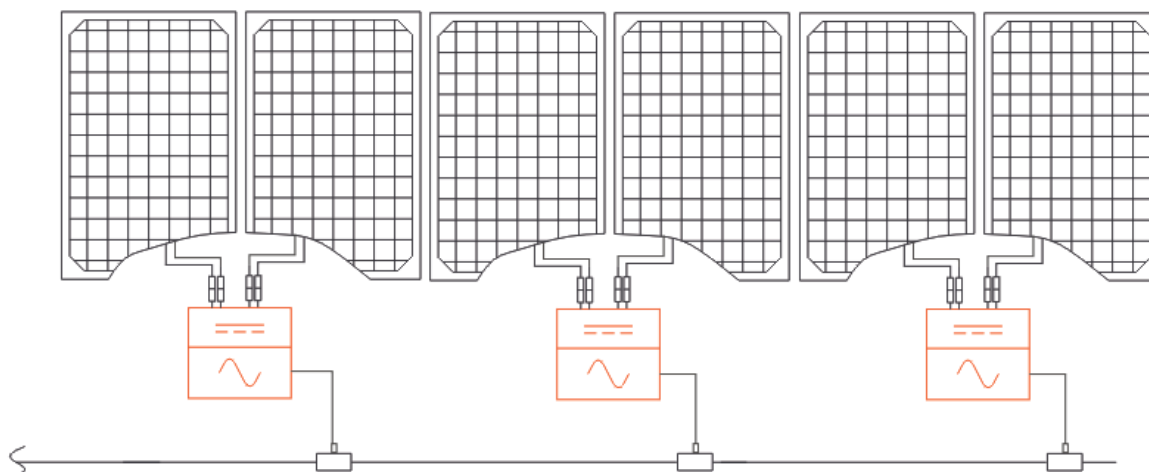

Datasheet | DS3 Microinverter Series

Model	DS3-S	DS3-L	DS3
Region	USA / Canada		
Input Data (DC)			
Recommended PV Module Power (STC) Range	250Wp-480Wp+	265Wp-570Wp+	300Wp-660Wp+
Peak Power Tracking Voltage	28V-45V		
Operating Voltage Range	26V-60V		
Maximum Input Voltage	60V		
Maximum Input Current	16A x 2	18A x 2	20A x 2
Maximum input short circuit current	20A per input	22.5A per input	25A per input
Output Data (AC)			
Maximum Continuous Output Power	640VA	768VA	880VA
Nominal Output Voltage/Range ⁽¹⁾	240V / 211V-264V		
Nominal Output Current	2.66A	3.2A	3.7A
Maximum Output Fault Current (ac) And Duration	5.691Apk, 26.75ms of duration; 3.307Arms		
Nominal Output Frequency/ Range ⁽¹⁾	60Hz/58.8Hz-61.2Hz(HECO:57Hz-63Hz)		
Power Factor (Default/Adjustable)	0.99/0.8 leading...0.8 lagging		
Maximum Units per 12AWG Branch ⁽²⁾	6 (20A breaker)	5 (20A breaker)	4 (20A breaker)
Maximum Units per 10AWG Branch ⁽²⁾	9 (30A breaker)	7 (30A breaker)	6 (30A breaker)
Efficiency			
Peak Efficiency	97.3%		
CEC Efficiency	97%		
Nominal MPPT Efficiency	99.5%		
Night Power Consumption	20mW		
Mechanical Data			
Operating Ambient Temperature Range ⁽³⁾	-40°F to +149°F (-40°C to +65°C)		
Storage Temperature Range	-40°F to +185°F (-40°C to +85°C)		
Dimensions (W x H x D)	10.3" x 8.6" x 1.6" (263mm x 218mm x 41.2mm)	10.3" x 8.6" x 1.7" (263mm x 218mm x 42.5mm)	
Weight	5.7lbs(2.7kg)	6.8lbs(3.1kg)	
DC Connector Type	Stäubli MC4 PV-ADBP4-S2&ADSP4-S2		
Cooling	Natural Convection - No Fans		
Enclosure Environmental Rating	Type 6		
Features			
Communication (Inverter To ECU) ⁽⁴⁾	Encrypted ZigBee		
Isolation Design	High Frequency Transformers, Galvanically Isolated		
Energy Management	Energy Management Analysis (EMA) system		
Warranty ⁽⁵⁾	10 Years Standard ; 25 Years Optional		
Compliance			
Safety and EMC Compliance	UL1741; CSA C22.2 No. 107.1-16; UL1741SA; UL1741SB; IEEE1547; Rule 21; SRD-V2.0; FCC Part15; ICES-003; NEC2014&NEC2017&NEC2020 Section 690.11 DC Arc-Fault circuit Protection; NEC2014&NEC2017&NEC2020 Section 690.12 Rapid Shutdown of PV systems on Buildings		

(1) Nominal voltage/frequency range can be extended beyond nominal if required by the utility.
 (2) Limits may vary. Refer to local requirements to define the number of microinverters per branch in your area.
 (3) The inverter may enter to power de-grade mode under poor ventilation and heat dissipation installation environment.
 (4) Recommend no more than 80 inverters register to one ECU for stable communication.
 (5) To be eligible for the warranty, ASystems microinverters need to be monitored via the EMA portal. Please refer to our warranty T&Cs available on usa.ASystems.com.

© All Rights Reserved
 Specifications subject to change without notice please ensure you are using the most recent update found at web : usa.ASystems.com

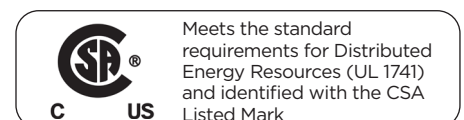



Certificate of Compliance

Certificate: 80069963

Master Contract: 259077

Project: 80125194

Date Issued: 2022-05-28

Issued to: Altenergy Power System Inc.
No.1 Yatai Road
Jiaxing, Zhejiang, 314050
CHINA

Attention: Kevin Lu

The products listed below are eligible to bear the CSA Mark shown with adjacent indicators 'C' and 'US' for Canada and US or with adjacent indicator 'US' for US only or without either indicator for Canada only



Issued by: *Magic Zhang*
Magic Zhang

PRODUCTS

CLASS - C531109 - POWER SUPPLIES - Distributed Generation Power Systems Equipment

CLASS - C531189 - POWER SUPPLIES - Distributed Generation-Power Systems Equipment - Certified to U.S. Standards

Grid Support Utility Interactive Microinverter, Models DS3-H, DS3, DS3-L and DS3-S, rack mounted.

For details related to rating, size, configuration, etc., reference should be made to the CSA Certification Record, Certificate of Compliance Annex A, or the Descriptive Report.

APPLICABLE REQUIREMENTS

CSA-C22.2 No.107.1-16 - Power Conversion Equipment
*UL Std No. 1741-Third Edition - Inverters, Converters, Controllers and Interconnection System Equipment for Use With Distributed Energy Resources (Third Edition, Dated September 28, 2021)



Certificate: 80069963
Project: 80125194

Master Contract: 259077
Date Issued: 2022-05-28

***Note:** Conformity to UL 1741(Third Edition, Dated September 28, 2021) includes compliance with applicable requirements of IEEE 1547-2003 (R2008), IEEE 1547.1-2005(R2011), California Rule 21 and Supplement SA8-SA18.

***Note:** This product is PV Rapid Shut Down Equipment and conforms with NEC-2014, NEC-2017 and NEC-2020 Article 690.12 and CEC-2018, CEC-2021 Sec 64-218 Rapid Shutdown of PV Systems, for AC and DC conductors, when installed according manufacturer's instructions.

Notes:

Products certified under Class C531109 have been certified under CSA's ISO/IEC 17065 accreditation with the Standards Council of Canada (SCC). www.scc.ca



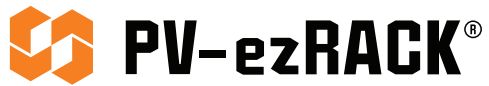

Designed for Canada



SolarTerrace III-A

A versatile fixed-tilt ground-mount solar racking system designed to suit challenging Canadian environments and soil conditions Last



 **SOLAR TERRACE**

Last Updated - Oct 2024

SolarTerrace III-A

A universal and earthed ground mount frame designed for corrosive environments and challenging soil conditions

Manufactured from high-quality structural-grade anodized aluminum, the PV-ezRack® SolarTerrace III-A (STIII-A) is the ideal mounting solution for locations across the vast Canadian landscape. The support legs, complete with girder caps, can be installed using helical piles, concrete ballast or other pre-engineered foundations suited to local soil conditions. Its user-friendly prefabrication simplifies installation, making it practical for both commercial projects and residential installations.

Key Benefits

Preassembled Support Legs

The support legs of the STIII-A are fully preassembled. They only need to be unfolded and secured to the foundation. This design saves valuable time in assembly and logistics, making it one of the fastest systems on the market.

Engineered for Canada

The ST III-A is designed to withstand Canada's diverse climate conditions, ensuring reliable performance in extreme temperatures and heavy snow loads. Its adaptable support legs can be installed with concrete ballast or screw pile, making it suitable for challenging soil conditions across the country. The standardised supports for Canada are designed at 30° and 45° and can accommodate panels up to 2400mm, subject to panel clamping zones.

Durable in Harsh Environments

The STIII-A is constructed from 6005 aluminum alloy with 304 stainless steel fasteners (316 stainless steel available upon request), making it ideal for the toughest environments, including corrosive sites near coastlines.

Full Grounding Function

The STIII-A features a UL-compliant grounding system. With pre-fitted pressure bolts and star washers in the preassembled supports, it ensures earthing continuity from the T-Rail to the support, providing a fully grounded system. Furthermore, the grounded Akashi module clamps, which can be used as mid or end clamps for panel frame heights of 30-46mm, make installations and logistics easier.

Technical Details

Configuration	Preassembled and modular; standard 30° and 45° tilt with customized options available
Tilt Angle	30° - 45°
Tilt Mechanism	Fixed
Base Compatibility	Concrete ballast footings and screw piles
East West Slope Tolerance	3° as standard and up to 30° with E-W adapters
Material	Aluminum alloy and stainless steel

Commercial

Residential

12 Panels per man-hour (foundation excluded)

25 YEAR WARRANTY
— BUILT TO LAST —



Designed for Canada



ER-R-T110
T-Rail 110

The rail profile has been specifically developed to achieve larger spans reducing the number of legs to be installed. These have a Z-Module channel for panel mounting and are secured with the Rail Clamps to the support legs.



ER-RC-T/G
Rail Clamp for T-Rail with grounding /earthing pins

Rail-Clamps establish a secure connection between support legs and rails with our patented Z-Module technology. Available with grounding pins for earthing.



ER-S-STIII A
Support

The STIII-A supports are completely pre-assembled, they only need to be unfolded and secured to the foundation. The anodised aluminium alloy profiles are connected with stainless steel fasteners. Furthermore through this new design the legs can be adjusted vertically by 50mm allowing for adjustments in case the foundation requires it.

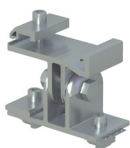
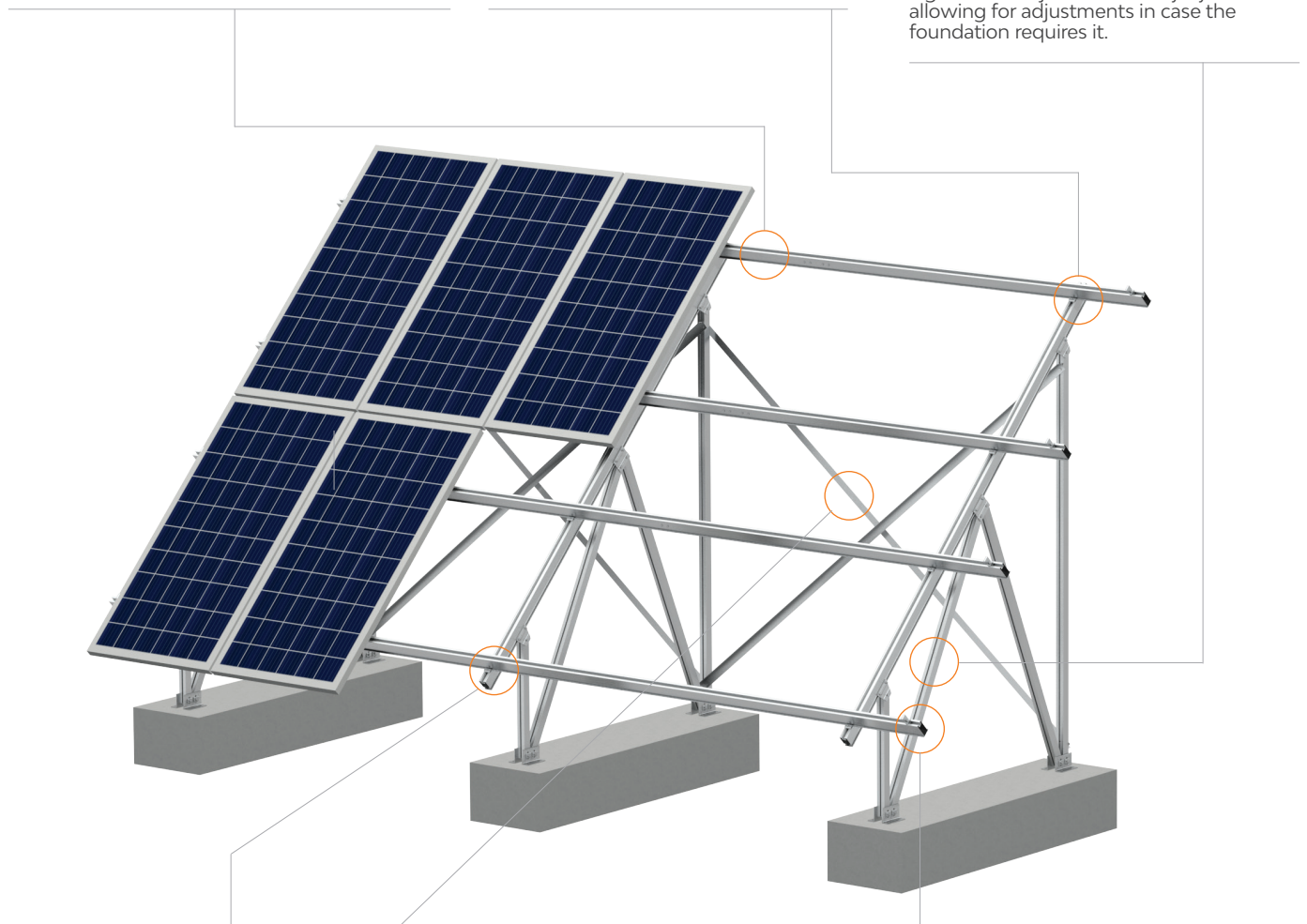

BR-R110/EW/G (optional)
East/West Adjustable Bracket for T-Rail 110 with grounding

The East/West Adjustable Bracket is specially designed for the projects installed in sloped areas and can significantly reduce the installation accuracy along east-west direction.



ER-AA-50/4250
Angle AL

The Angle AL as a reinforcement to make the system suitable for even harsh environments.



Akashi Clamp
C-U/30/46

PVezRack® Akashi Clamp, with dual functionality (inter and end clamp), is applicable with most common framed PV modules from 30 mm to 46mm in height. Inbuilt grounding clip is also available.

Available accessories

- Cable clips
- Cable trays
- Inverter/joint box bracket
- Rail and girder caps

Materials
AL6005-T5 | SUS304

Contact us or one of our qualified resellers for a personalised quotation today.





PV-ezRACK®

Clenergy

3/10 Duerdin St
Clayton VIC 3168
Australia

Phone: +61 3 9239 8088
Email: sales@clenergy.com.au
Web: www.clenergy.com.au

 @ClenergyGlobal / @ClenergyClub / ClenergyAUS  @Clenergy  @ClenergyClub
 @Clenergy_global  @Clenergy

A Clenergy Technologies Company





SolarTerrace III-A

Code-Compliant Planning and Installation V 4.1



Last Updated - Oct. 2024

Introduction

Clenergy PVezRack® SolarTerrace III-A is a pre-assembled ground mount system suitable for large scale commercial and utility scale installations. PVezRack® SolarTerrace III-A has been developed to fit any PV module. The innovative and patented SolarTerrace III-A T-Rails simplify and improve the accuracy of the installation. Using high quality engineered components SolarTerrace III-A saves developers and installers, time and money when delivering large scale projects.

Please review this manual thoroughly before installing your SolarTerrace III-A system. This manual provides

1) Simple introduction of the installation relating to PVezRack® SolarTerrace III-A Mounting systems.

2) Planning and installation instructions for SolarTerrace III-A.

SolarTerrace III-A parts, when installed in accordance with this guide, will be structurally sound and meet the National Building Code of Canada 2020, Ontario Building Code 2012 with 2022 amendments & Ontario Building Code 2024, British Columbia Building Code 2018 & British Columbia Building Code 2024, National Building Code-Alberta Edition 2019 & Alberta Edition 2023, National Building Code 2010 with Manitoba Amendments, CAN/CSA S157-17, "Strength Design in Aluminum, CAN/CSA S16-14(R2019), "Design of Steel Structures" standard. During installation please comply with the appropriate safety regulations, and please also comply with the relevant regulations of your local region.

Please check that you are using the current version of the Installation Manual by contacting Clenergy Australia by email on www.clenergy.com.au or your local representative.

Product Warranty:

Please refer [PVezRack® Product Warranty](#) on our website.

List of contents

Introduction	01
Tools & Components	02
System Overview	04
Installation Instruction	06

The installer is solely responsible for:

- Complying with all applicable local or national building codes, including any that may supersede this manual;
- Ensuring that PV-ezRack® and other products are appropriate for the particular installation and the installation environment;
- Using only PV-ezRack® parts and installer supplied parts as specified by PV-ezRack® (substitution of parts may void the warranty and invalidate the letter of certification);
- Recycle according to the local relative statute;
- Removal: Reverse installation process;
- Ensure that there are no less than two professionals working on panel installation;
- Ensure the installation of all electrical equipment is performed by licensed electricians;

Introduction

Clenergy PVezRack® SolarTerrace III-A is a pre-assembled ground mount system suitable for large scale commercial and utility scale installations. PVezRack® SolarTerrace III-A has been developed to fit any PV module. The innovative and patented SolarTerrace III-A T-Rails simplify and improve the accuracy of the installation. Using high quality engineered components SolarTerrace III-A saves developers and installers, time and money when delivering large scale projects.

Please review this manual thoroughly before installing your SolarTerrace III-A system. This manual provides

1) Simple introduction of the installation relating to PVezRack® SolarTerrace III-A Mounting systems.

2) Planning and installation instructions for SolarTerrace III-A.

SolarTerrace III-A parts, when installed in accordance with this guide, will be structurally sound and meet the National Building Code of Canada 2020, Ontario Building Code 2012 with 2022 amendments & Ontario Building Code 2024, British Columbia Building Code 2018 & British Columbia Building Code 2024, National Building Code-Alberta Edition 2019 & Alberta Edition 2023, National Building Code 2010 with Manitoba Amendments, CAN/CSA S157-17, "Strength Design in Aluminum, CAN/CSA S16-14(R2019), "Design of Steel Structures" standard. During installation please comply with the appropriate safety regulations, and please also comply with the relevant regulations of your local region.

Please check that you are using the current version of the Installation Manual by contacting Clenergy Australia by email on www.clenergy.com.au or your local representative.

Product Warranty:

Please refer [PVezRack® Product Warranty](#) on our website.

List of contents









Introduction	01
Tools & Components	02
System Overview	04
Installation Instruction	06

The installer is solely responsible for:









- Complying with all applicable local or national building codes, including any that may supersede this manual;
- Ensuring that PV-ezRack® and other products are appropriate for the particular installation and the installation environment;
- Using only PV-ezRack® parts and installer supplied parts as specified by PV-ezRack® (substitution of parts may void the warranty and invalidate the letter of certification);
- Recycle according to the local relative statute;
- Removal: Reverse installation process;
- Ensure that there are no less than two professionals working on panel installation;
- Ensure the installation of all electrical equipment is performed by licensed electricians;

Tools and Components

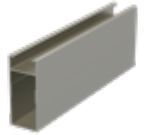

Tools

				
Allen Key 6 mm (M8Hexagon Socket Screw)	Electric Drill (ST4.8x16 self-tapping screw & M8 Hexagon Socket Screw)	Tape	Torque Wrench	String
				
Mark Pen	Wrench	Socket Wrench M8/M12	Total Station or Equivalent Instrument	

Components

				
ER-EC-ST End Clamp	ER-IC-ST Inter Clamp	ER-R-T110 T -Rail110	ER-SP-T110 Splice for T-110 Rail	ER-RC-T Rail Clamp for T Rail
				
ER-S-STIIIA Support (Pre-assembled)	ER-CAP-T110 Cap for T-110 Rail	ER-CAP-G/A Cap for Square Girder	EZ-GC-ST Grounding Clip	EZ-GL-ST Grounding Lug

Components

				
<p>C-U/30/46-G Akashi Clamp for Frame Height 30-46mm with Grounding Clip</p>	<p>C-U/30/46 Akashi Clamp for Frame Height 30-46mm</p>	<p>BR-R110/EW/G (Optional) PVezRack® East/West Adjustable Bracket for T-Rail 110 with grounding</p>	<p>ER-AA-50 Angel AL</p>	<p>GE-STA/200 (Optional) Girder Extension</p>

System Overview

Overview of PVezRack® SolarTerrace III-A

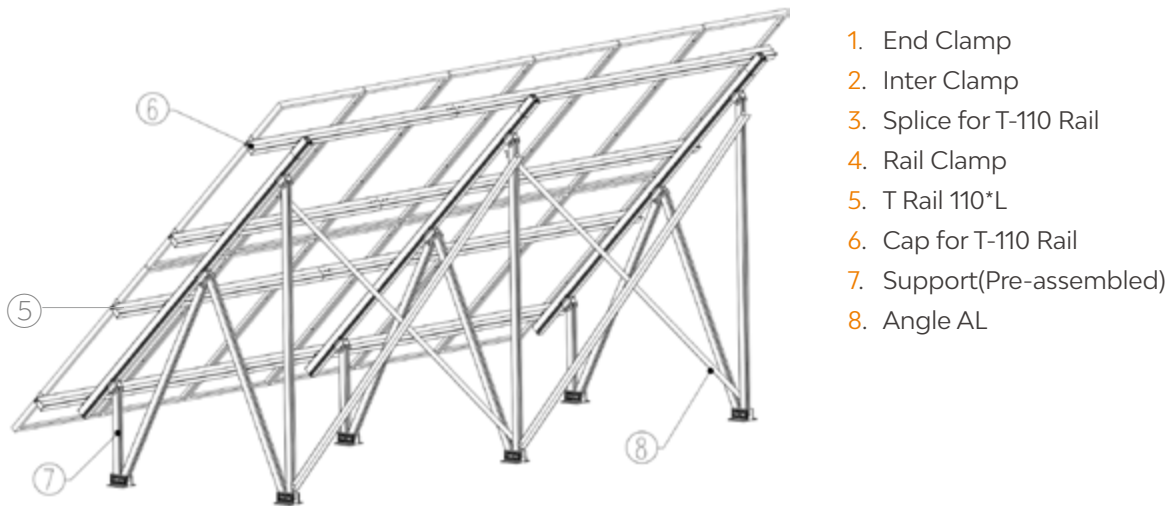

- 1. End Clamp
- 2. Inter Clamp
- 3. Splice for T-110 Rail
- 4. Rail Clamp
- 5. T Rail 110*L
- 6. Cap for T-110 Rail
- 7. Support (Pre-assembled)
- 8. Angle AL

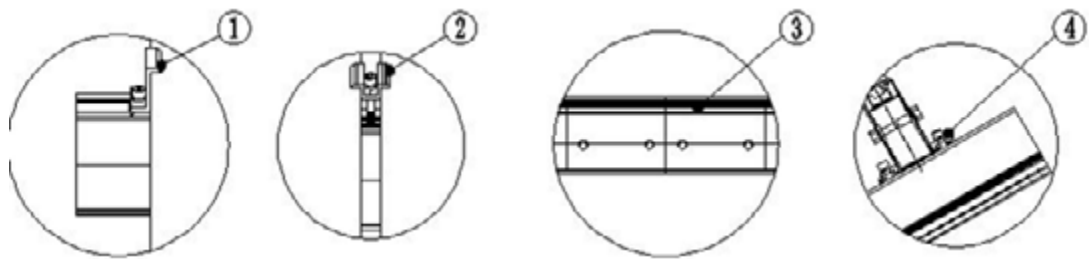

Precautions during Stainless Steel Fastener Installation

Improper operation may lead to deadlock of Nuts and Bolts. The steps below should be applied to stainless steel nut and bolt assembly to reduce this risk.

General installation instructions

- (1) Apply force to fasteners in the direction of thread
- (2) Apply force uniformly, to maintain the required torque
- (3) Professional tools and tool belts are recommended
- (4) In some cases, fasteners could be seized over time. As an option, if want to avoid galling or seizing of thread, apply lubricant (grease or 40# engine oil) to fasteners prior to tightening.

Safe Torques

Please refer to safe torques defined in this guide as shown in the figure below. If power tools are required, Clenergy recommends the use of low speed only. High speed and impact drivers increase the risk of bolt galling (deadlock). If deadlock occurs and you need to cut fasteners, please make sure that there is no load on the fastener before you cut it. Avoid damaging the anodized or galvanized surfaces.

These steps should be applied for every stainless steel nut and bolt assembly.

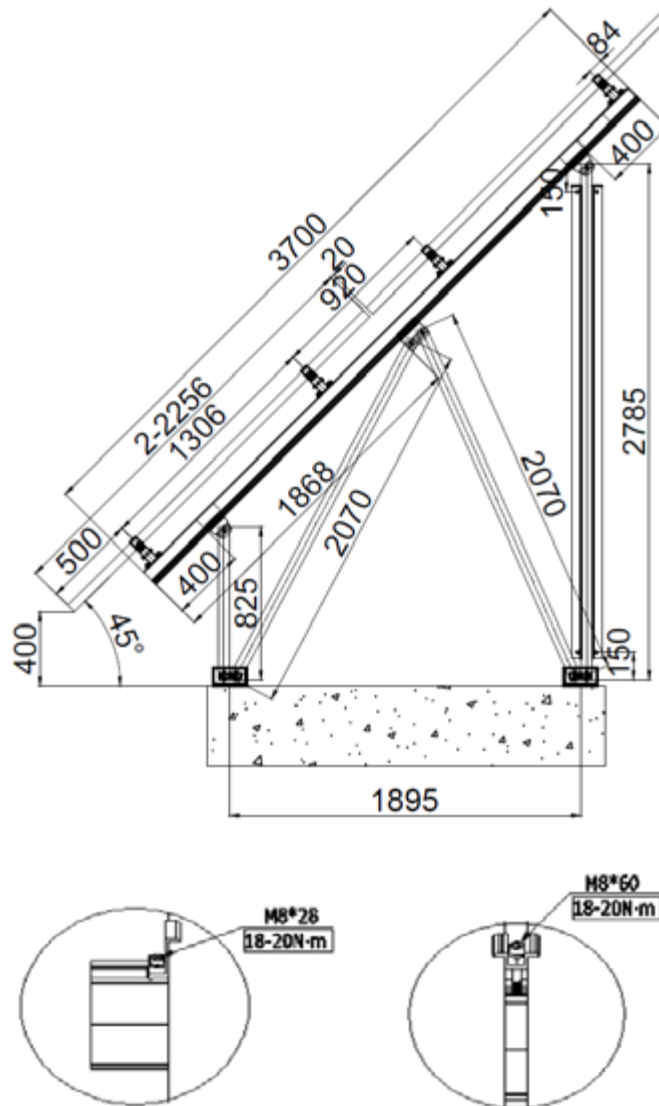

Safe Torques

Installation Dimensions

All drawings and dimensions in this installation guide are for a generic reference. PV-ezRack® SolarTerrace III-A is to be optimized to suit specific conditions for each project and documented in a construction drawing. As a result, major components of PV-ezRack® SolarTerrace III-A may be provided in section sizes and lengths that vary from those shown in this guide. The installation process detailed in this instruction guide remains the same regardless of the component size. In case you need to do any on-site modifications or alteration of the system in a way that would be different from the construction drawing please provide marked up drawings/sketches for Clenergy’s review prior modification for comment and approval.

Installation Instructions

Pre-assembled Support Installation

Unfold the Pre-assembled Support

Solution 1 (For 30 degree tilt support)

Step 1:

Unfold the pre-assembled support as shown in Fig. 2;

Step 2:

Unfold the Slotted Al-Tube as shown in Fig.3;

Step 3:

Unlock the M12*100 bolts from the H Joint first and fasten the Al-Tube and H Joint lightly with M12*100 again as shown in Fig.4;

Step 4:

Rotate the L-anchor and U-anchor plates to ensure they align as shown as Fig. 5.

Note:

The bolt heads have to be kept in same direction.



Fig. 1

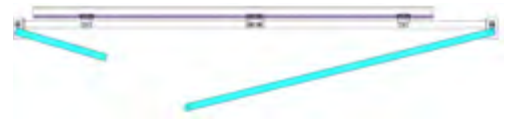

Fig. 2

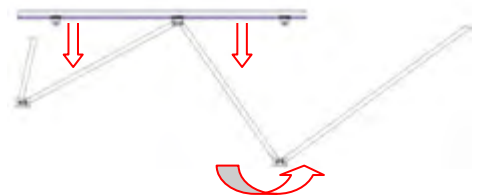

Fig. 3

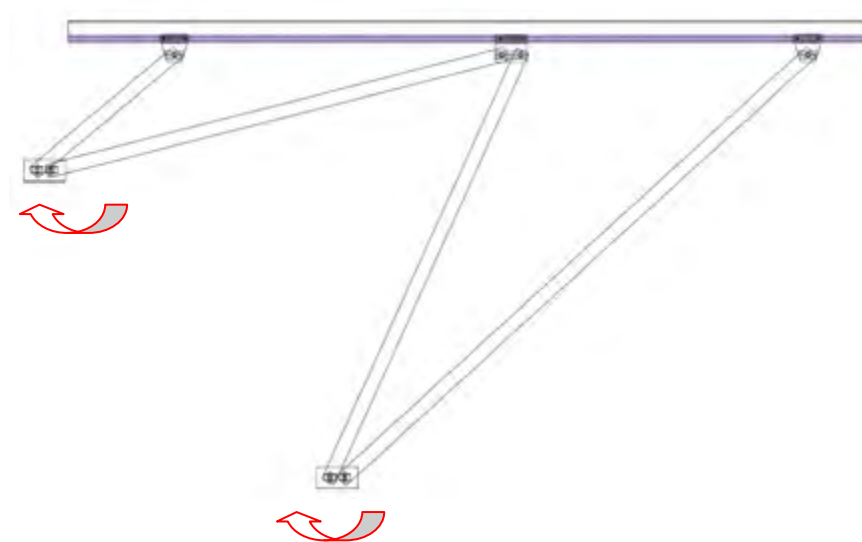

Fig. 4



Fig. 5

Fix the Pre-assembled Support to the Concrete Footings.

Connect the Pre-assembled Support and Concrete Footings by using embedded M16 (Grade 5.8 Carbon Steel anchor studs or similar). Adopt the minimum anchor embedded depth according the anchors manufacturer's Manual. The up-down adjustable range of the Front/Rear leg is $\pm 20\text{mm}$. The north-south adjustable range of the Front/Rear leg is $\pm 7.5\text{mm}$.

Recommended Torque:
M16: 135~150N·m

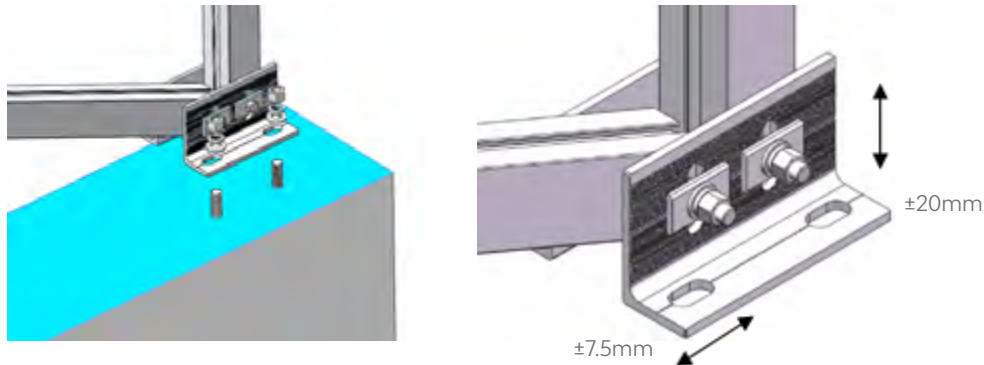

Fig. 6

Check the System and Fasten all Bolts with Recommended Torque (please refer to Page 5).

Recommended
Torque: M8 Bolt: 13N·m;
M8 Nut: 18~20N·m
M12: 40~45N·m

According to Engineering Drawing, Repeat the Above Operations to Install Other Pre-assembled Supports

Ensure all the Tri-Groove Beams of Pre-assembled Support are aligned and all Pre-assembled Supports are parallel to each other.
Now fasten all bolts tightly.

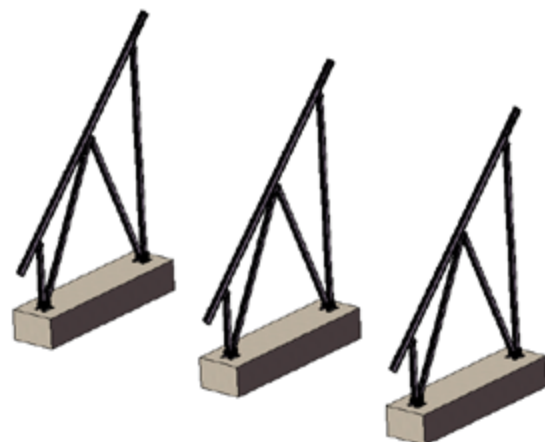

Fig. 7

T Rail Installation

Direct Installation

According to the engineering drawing, mark the locations for the Rail on the Tri-groove beam. The dimensions shown in the figure on the right is an example.

Slide the T Rail on to the Tri-Groove Beam. Apply one Rail Clamp to the T Rail on each side of Rail, and fasten lightly with the 6mm Allen Key as shown in the Figures below.

Recommended Torque:

M8: 18~20N·m

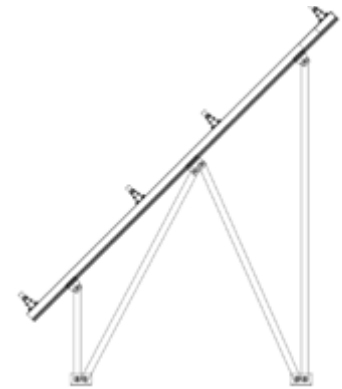

Fig. 8



Fig. 9



Fig. 10

Note:

If the Pre-assembled Support has pre-positioned Rail Clamps for the T Rail, slide another Rail Clamp in other side of the T Rail.

If the T Rail is not long enough, connect two T Rails together using the Splice for the T-110 Rail as shown in the diagram below. Insert half of the Splice into the T Rail and fasten with two sets of Selftapping screws in each side of the T Rail, and then insert the other Splice into the T Rail and again fasten with Self-tapping screws. To prevent thermal expansion problems, the Rails shall not exceed 30m long.

Note:

Please fasten the Self-tapping screw until the rubber washer grips firmly, attaching the T Rails tightly onto the splice.

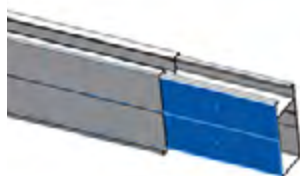

Insert half of Splice into the T Rail

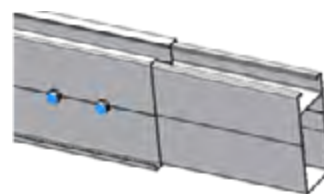

Then use two sets of Self-tapping screws in each side of the T Rail

Fig. 11



Insert half of the Splice into the T Rail

Two sets of Self-tapping screws each side of the T Rail

Fig. 12

Place the T Rails one by one in the planned position on the supports.

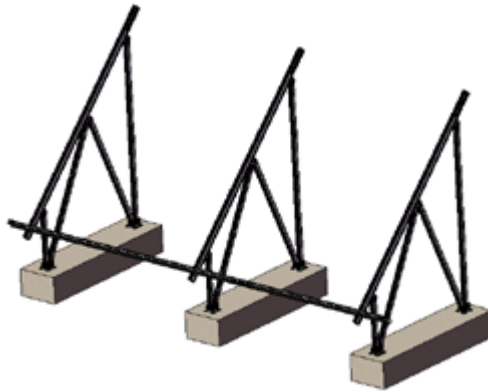

Fig. 13

Repeat the above operations and install all other T Rails. Ensure the end faces of the Rails are aligned and all Rails are at same height. Now fasten all the bolts tightly.

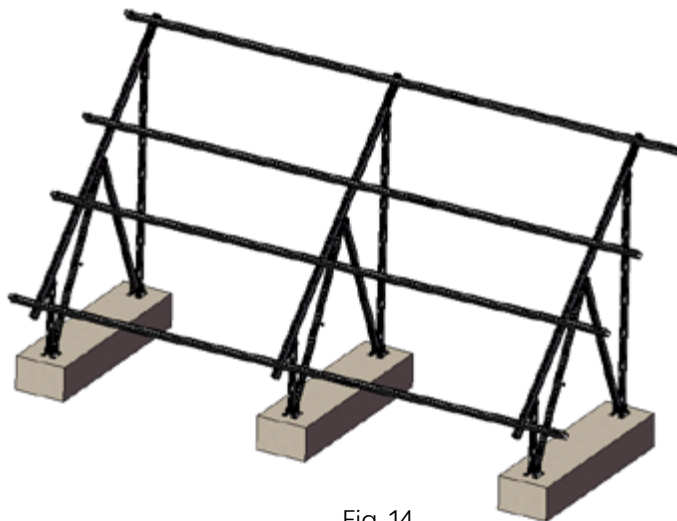

Fig. 14

East/West Adjustable Bracket Installation (optional)

Click the pre-assembled East/ West Adjustable Bracket into the Tri- Groove Beams and adjust properly as shown in Fig.15. Fasten the M8 bolt slightly with the Allen key.



Fig. 15

Click the corrugated shim and Z Mould/bolt into the Tri-Groove Beams and move them into the opening slot hole of East/West Adjustable Bracket. After the bolt is at the end of slot hole, fasten the M8 bolts slightly as shown in Fig. 16.

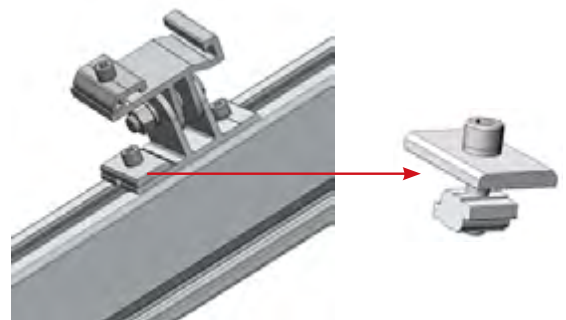

Fig. 16

Repeat above steps to install other East/West Adjustable Brackets. Adjust all brackets and make the brackets sit at the right positions.

Now fasten all M8 bolts tightly within 18~20 N·m.

Tilt the T Rail to a certain angle and slide into the groove of East/West Adjustable Brackets of the same height on the Tri-Groove Beams. Then use a 6mm Allen key (Hex) to fasten on another side via Rail Clamp for T-Rail. Fasten all the M12 bolts on the East/ West Adjustable Brackets.

Recommended Torque:

M8: 18~20 N·m

M12: 50~55 N·m

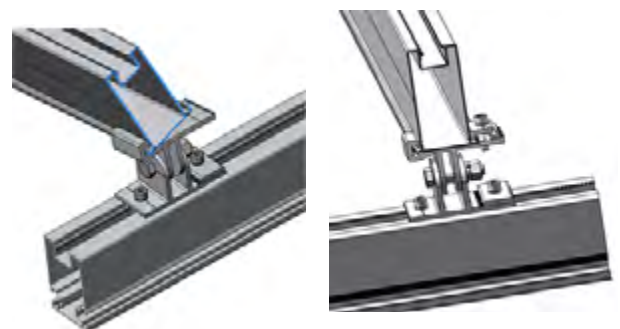

Fig. 17

Angle AL Installation (optional)

Apply T-head bolt M8*25 for Angle AL installation. Slide the bolt head into the U-slot of Slotted Al-Tube and rotate the bolt slightly as shown in right Figures.

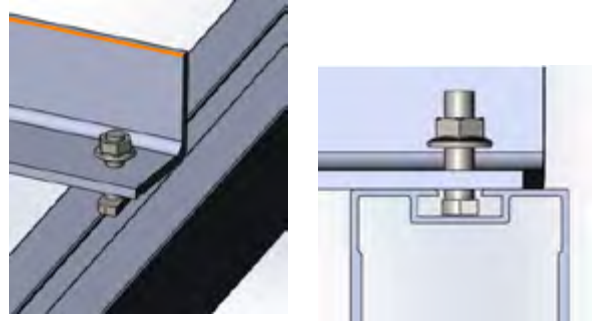

Fig. 18

Fasten the bolts slightly after the installation position is determined.

Repeat above steps to install all Angle AL.

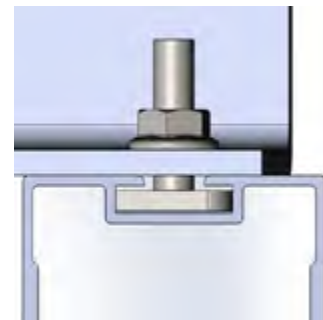

Fig. 19

Girder Extension Installation (optional)

Connect the Girder Extension by using Flange Facing Self-Tapping Screw (Washer) ST6.3*22.

Note:

Please fasten the Self-tapping screw until the rubber washer attach the Girder tightly.



Fig. 20

The whole installation is completed now as shown in right Figure.

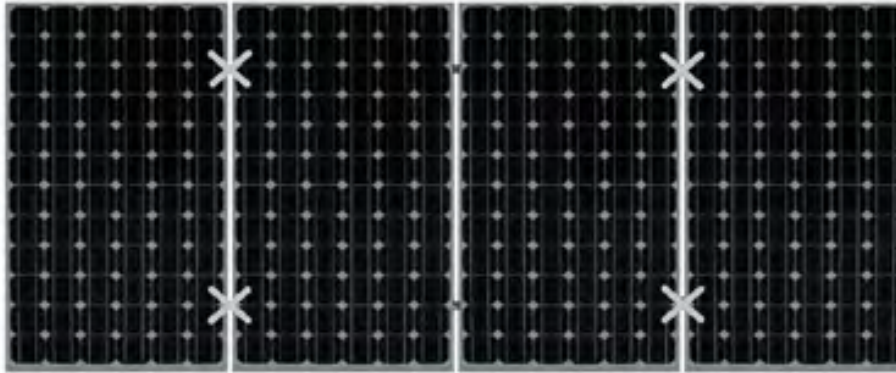

Fig. 21

PV Module Installation

Deployment of Grounding Clip (Even and Odd)

1) When there is an even number of PV Module in each row



Install the Grounding clips at the positions marked X in the figure shown. Then the number of Grounding clips = number of PV Modules. Eg: 4 Grounding clips in the figure shown.

2) When there is an odd number of PV Module in each row

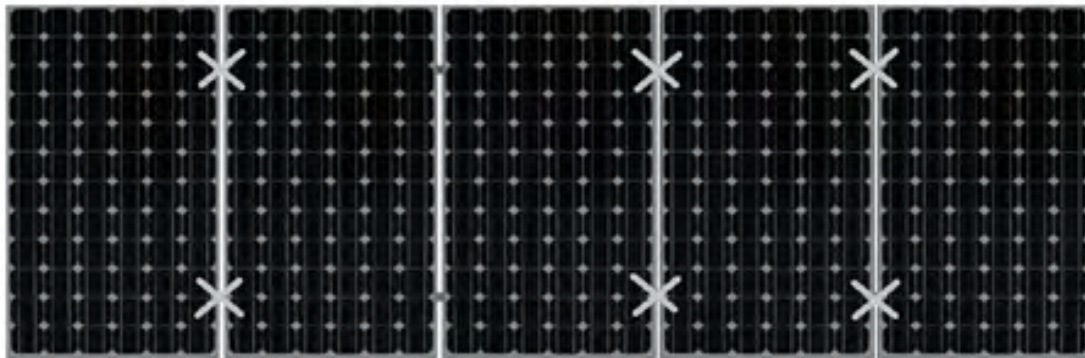

Install the Grounding clips at the positions marked X in the figure shown. Then the number of Grounding clips = number of PV Modules +1. Eg: 6 Grounding clips in the figure shown.

Key point:

When replacing a defective single PV Module, it is required to replace the Grounding Clip under the PV Module, as they are intended for single use only.

Note: Please refer to Grounding System Installation for other options of grounding clip arrangement

Place the PV Modules on the Rails, and fix them with End Clamps and Inter Clamps or Universal Clamps, then fasten them with the Allen key. Please choose either Solution 1 or 2 below, according to your project.

Solution 1 (Apply End Clamps and Inter Clamps)

Step 1:

Place the first PV Module on the T Rails according to your plan and apply the End Clamps to fix it in place. Then fasten lightly with the Allen Key as shown in Fig. 22.

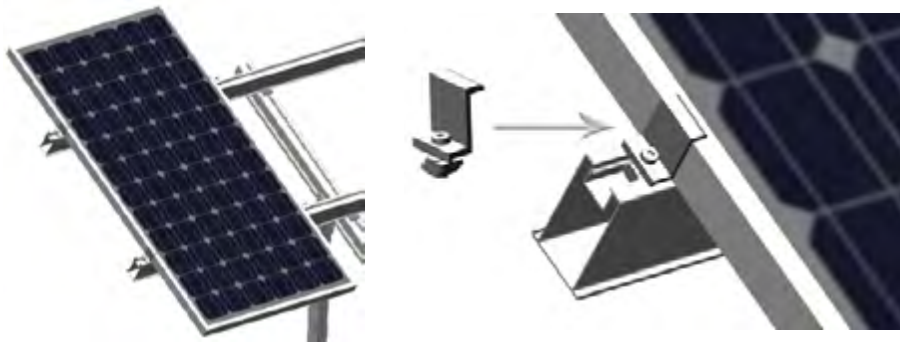

Fig. 22

Step 2:

Slightly lift the PV Module and slide the Inter Clamps and Grounding Clips into position. The teeth on Grounding Clip will be automatically aligned when the Inter Clamp is properly installed as shown in Fig. 23.

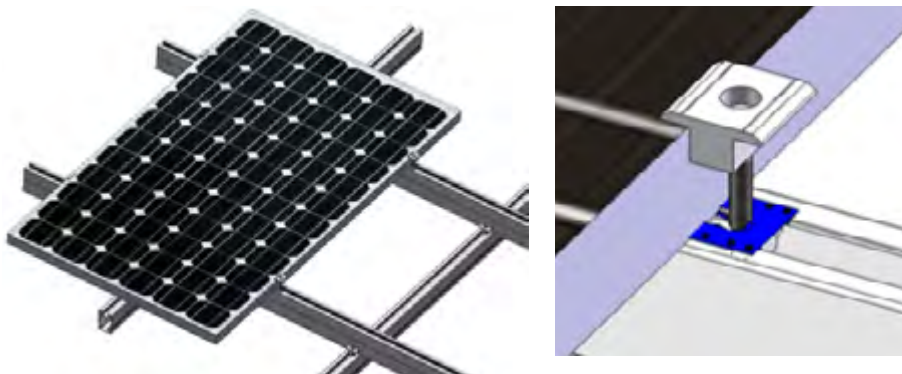

Fig. 23

Step 2:

Slightly lift the PV Module and slide the Inter Clamps and Grounding Clips into position. The teeth on Grounding Clip will be automatically aligned when the Inter Clamp is properly installed as shown in Fig. 23.

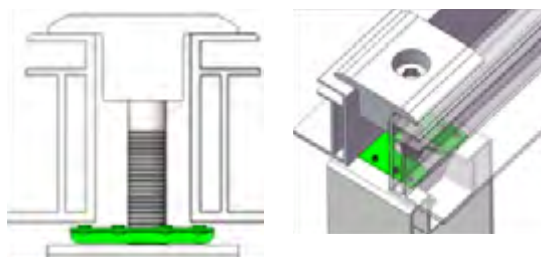

Fig. 24

Important Notes:

To fix the Grounding Clip properly, ensure the frames of the PV Modules are now firmly pressed against the Inter Clamp and Grounding Clip and visually check that Grounding Clips are positioned properly. (Grounding Clips are intended for SINGLE USE ONLY!) Only fasten the bolts down when you are sure the PV modules are in the correct position and lightly tighten the bolts at this stage to keep the PV Modules in place.

Step 4:

When using End and Inter clamps, maintain 20mm vertical gap and 18/20mm horizontal gap (as per design drawings) between the two adjacent rows of PV Modules. You can use two Inter Clamps as separation between two PV Modules to achieve this and remove them after the installation is completed as shown in Fig. 25.

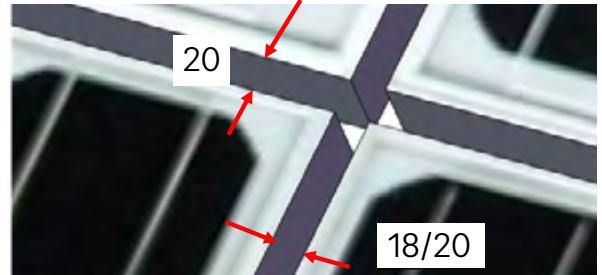

Fig. 25

Step 5:

Repeat the above steps to install all PV Modules. Fasten all the End and Inter Clamps tightly with 18~20N.m until all the PV Modules are correctly installed.

Solution 2 (Apply Universal Clamps)

Step1:

Twisting the head of the Universal Clamp changes the functionality from end to inter clamp as shown in Fig. 26.

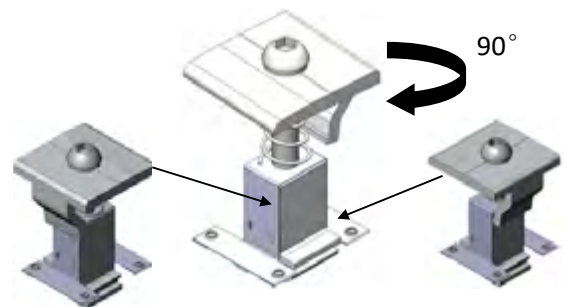

Fig. 26

Note:

Please ensure the Universal Clamp C-U/30/46 or Universal Clamp with Grounding clip C-U/30/46-G is positioned correctly according to Deployment of Grounding clip.

Step 2:

Incline the Universal Clamp to place the channel on its lower part against the lower channel of the T Rail. Then press the Universal Clamp down towards the other side of the T Rail to engage the channel on its upper part against the upper channel of T Rail as shown in Fig. 27.

Note:

Before installation, make sure there will be enough clearance between the screw and module of Universal Clamp as shown in Fig. 27 (next page).

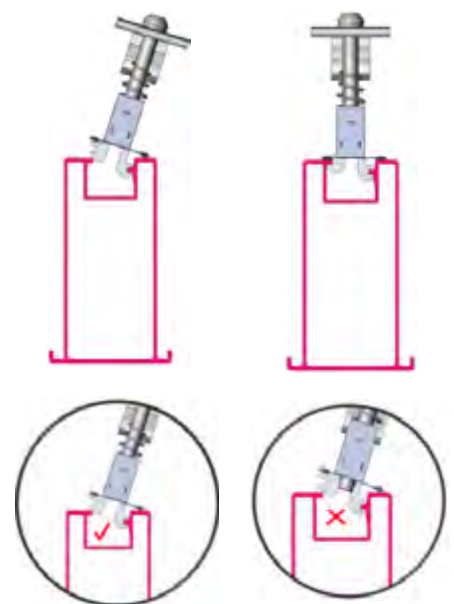

Fig. 27

Step 3:

Place the first PV Module on the T Rails and position the Universal Clamp as an End Clamp to fix it and then fasten lightly with Allen Key. Make sure the frame of the PV Module is fully in contact with the Universal Clamp as shown in Fig.28. Visually check the Universal Clamp and PV module are correctly installed.

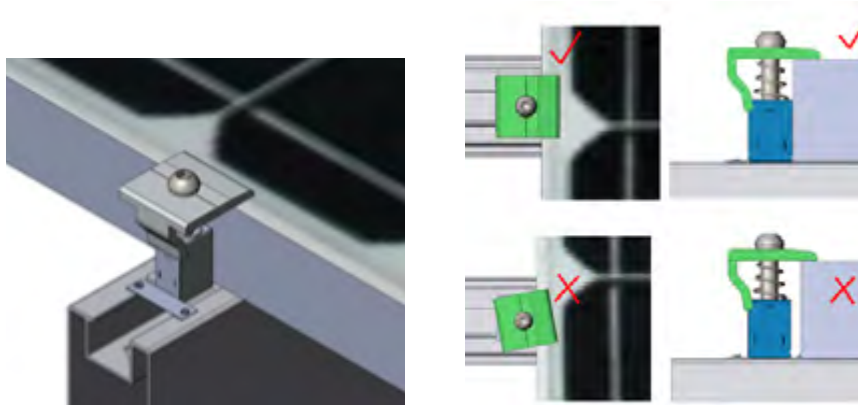

Fig. 28

Step 4:

When using as Inter Clamp, click the Universal Clamp into the channel of T Rail and then slightly lift the framed PV Module to make sure the Grounding Clip of Universal Clamp is fully covered as shown in Fig. 29.

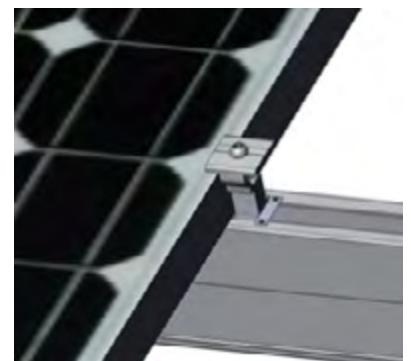

Fig. 29

Step 5:

Place the next framed PV Module into the other side of Universal Clamp. Make sure the Grounding Clip of the Universal Clamp will be fully covered and ensure the frame of PV Module is closely in contact with Universal Clamp as shown in Fig. 30. Note the 20mm gap when using Universal Clamps.

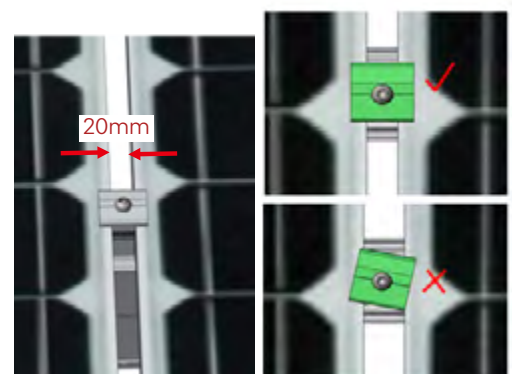

Figure 30

Step 6:

Repeat the above steps to install all PV Modules. Visually check the Universal Clamps and PV modules are properly positioned and then tighten all Clamps.

The recommend torque for Universal Clamps that are used as End Clamps is 13-14N·m. The recommend torque for Universal Clamps that are used as Inter Clamps is 18-20N·m.

Apply one pre-assembled Grounding Lug per T Rail. Click the Grounding Lug into the channel of the T Rail and insert the Copper Wire. (the maximum size is 6AWG or similar) Then fasten the bolt M6*10 with 10N·m and fasten the bolt M8*25 with 13.5N·m as shown in the Fig.31.



Figure 31

Now the installation is completed as shown in Fig.32. Please recheck all Bolts and fasten them tightly according to the recommended torque.



Figure 32



PV-ezRACK®

Clenergy

3/10 Duerdin St
Clayton VIC 3168
Australia

Phone: +61 3 9239 8088
Email: sales@clenergy.com.au
Web: www.clenergy.com.au

 @ClenergyGlobal / @ClenergyClub / ClenergyAUS  @Clenergy  @ClenergyClub
 @Clenergy_global  @Clenergy

A Clenergy Technologies Company

Hi-MO X6^{Max} Explorer

LR7-72HTH

605~615M

- Suitable for Distribution Market
- Simple design embodies modern style
- Highest efficiency with the best energy generation performance
- Better product warranty, better service



15-year Warranty for
Materials and Processing



25-year Warranty for Extra
Linear Power Output

Complete System and Product Certifications

IEC 61215, IEC 61730, UL 61730

ISO9001:2015: ISO Quality Management System

ISO14001: 2015: ISO Environment Management System

ISO45001: 2018: Occupational Health and Safety

IEC62941: Guideline for module design qualification and type approval

LONGI



22.8%
MAX MODULE
EFFICIENCY

0~3%
POWER
TOLERANCE

<1%
FIRST YEAR
POWER DEGRADATION

0.40%
YEAR 2-25
POWER DEGRADATION

Additional Value

25-Year Power Warranty

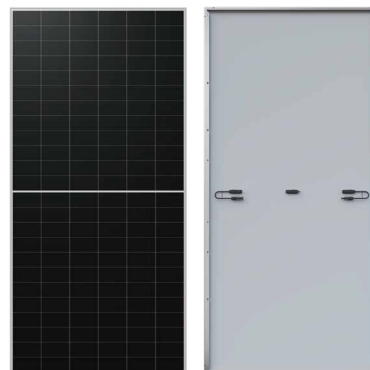
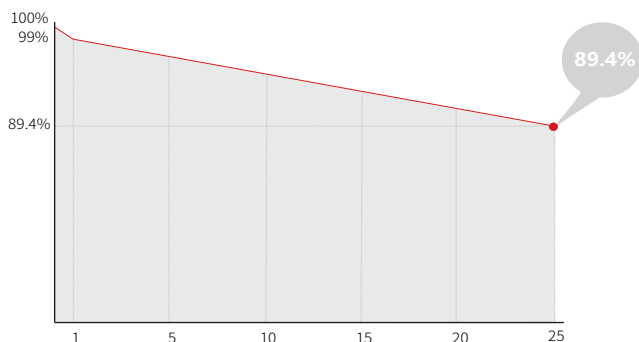

Mechanical Parameters

Cell Orientation	144 (6×24)
Junction Box	IP68
Output Cable	4mm ² , +400, -200mm/±1400mm length can be customized
Glass	Single glass, 3.2mm coated tempered glass
Frame	Anodized aluminum alloy frame
Weight	28.5kg
Dimension	2382×1134×30mm
Packaging	36pcs per pallet / 144pcs per 20' GP / 720pcs per 40' HC

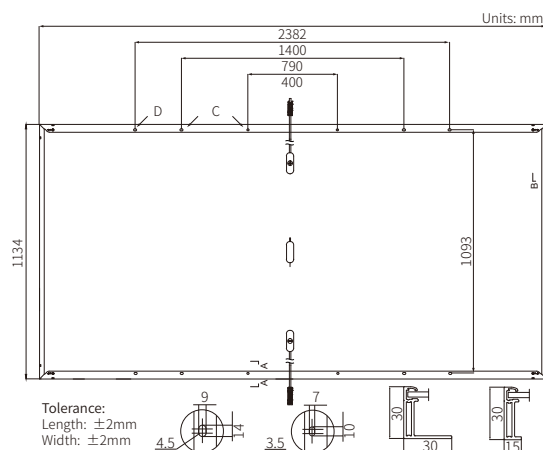

Electrical Characteristics

STC : AM1.5 1000W/m² 25°C

NOCT : AM1.5 800W/m² 20°C 1m/s

Test uncertainty for Pmax: ±3%

Module Type	LR7-72HTH-605M		LR7-72HTH-610M		LR7-72HTH-615M	
	STC	NOCT	STC	NOCT	STC	NOCT
Maximum Power (Pmax/W)	605	452.1	610	455.9	615	459.6
Open Circuit Voltage (Voc/V)	52.27	49.17	52.42	49.22	52.57	49.36
Short Circuit Current (Isc/A)	14.74	11.91	14.80	11.95	14.87	12.01
Voltage at Maximum Power (Vmp/V)	44.03	40.18	44.18	40.32	44.33	40.46
Current at Maximum Power (Imp/A)	13.75	11.26	13.81	11.31	13.88	11.36
Module Efficiency(%)	22.4		22.6		22.8	

Operating Parameters

Operational Temperature	-40°C ~ +85°C
Power Output Tolerance	0 ~ 3%
Maximum System Voltage	DC1500V (IEC/UL)
Maximum Series Fuse Rating	25A
Nominal Operating Cell Temperature	45±2°C
Protection Class	Class II
Fire Rating	IEC Class C

Mechanical Loading

Front Side Maximum Static Loading	5400Pa
Rear Side Maximum Static Loading	2400Pa
Hailstone Test	25mm Hailstone at the speed of 23m/s

Temperature Ratings (STC)

Temperature Coefficient of Isc	+0.050%/°C
Temperature Coefficient of Voc	-0.230%/°C
Temperature Coefficient of Pmax	-0.280%/°C

DEVELOPMENT PERMIT CIRCULATION MEMORANDUM

From: Foothills County
Box 5605 // 309 Macleod Trail
High River, AB T1V 1M7
planning@foothillscountyab.ca

File Number: 26D 075

Date: 9-Mar-2026

Landowner: John Howard Bye/Catherine Laumne Bye **Agent:** Bye Nuvo Renewables Inc.

Legal Land Description: NW 26-21-1 W5M;Plan 0110200, Block 3, Lot 7

Parcel Size: 4.57 Acre

Proposal: Solar Power System, Private

Enclosed is a copy of the plans for the above-mentioned development. We would appreciate receiving your comments on the proposal within 30 days of the date of this letter.

If you require further information or clarification, please contact the Development Department in High River at (403) 652-2341 by phone or through email using the below address. **Please quote our file name when returning your comments to the attention of our Development Department.** Thank you for your cooperation.

30 DAY CIRCULATION

Contact: **Brittany Smith** Brittany.Smith@FoothillsCountyAB.ca

Application to be referred to:

Division Councillor	_____	Economic Development	_____
Development Officer Site Insp.	_____	AB Comm. Development	_____
Alberta Health Services	_____	AB Energy Regulator	_____
Alberta Transportation	_____	AB Agriculture & Forestry	_____
AB Environment	_____	AB Agriculture, Sustainable Resource	_____
Public Works	X		
Building & Safety Codes	X	AB Agriculture, Public Lands Div.	_____
Municipal Fire Services	_____	Fortis Alberta	X
Municipal Addressing	_____	ATCO Gas	X
Municipal Community Services	_____	AltaLink	_____
AFICA	_____	Other:	_____
Erin Frey (HR Airport only)	_____		_____

Notes: _____



PLANNING & DEVELOPMENT CIRCULATION

PUBLIC WORKS DEPARTMENT – CIRCULATION RESPONSE

FILE NUMBER:	LANDOWNER:
FILE MANAGER:	AGENT:
CURRENT LAND USE:	PROPOSED LAND USE:
LEGAL DESCRIPTION:	
MUNICIPAL ADDRESS:	
[REDACTED]	
ROLL NUMBER:	
DATE REFERRED:	
PROPOSAL:	

PROPOSAL INFORMATION:

AMENDMENT

- Internal Road Proposed:
- Construction on Road Allowance Proposed:
- Approaches exist on:
 - Other:

Information pertaining to roads on _____ side of the subject lands:

_____ Servicing Comments or Review required:

- Other:
- Road Widening -

OTHER COMMENTS:

PUBLIC WORKS RECOMMENDATIONS:

SUGGESTED CONDITIONS FOR CONSIDERATION:

	Proposed	Balance	
<input type="radio"/> Geotechnical Report for Slope Stability	<input type="checkbox"/> Redes/Amend	<input type="checkbox"/> Subdivision	<input type="checkbox"/> Development
<input type="radio"/> High Water Table Testing for Foundation Design:	<input type="checkbox"/> Redes/Amend	<input type="checkbox"/> Subdivision	<input type="checkbox"/> Development
<input type="radio"/> Septic Disposal Evaluation (PSTS)	<input type="checkbox"/> Redes/Amend	<input type="checkbox"/> Subdivision	
<input type="radio"/> Stormwater Management Plan	<input type="checkbox"/> Redes/Amend	<input type="checkbox"/> Subdivision	<input type="checkbox"/> Development
<input type="radio"/> Lot Grading/Overland Drainage Plan	<input type="checkbox"/> Redes/Amend	<input type="checkbox"/> Subdivision	<input type="checkbox"/> Development
<input type="radio"/> Flood Plain Report (1 in 100 years)	<input type="checkbox"/> Redes/Amend	<input type="checkbox"/> Subdivision	<input type="checkbox"/> Development
<input type="radio"/> Overland Drainage Easement	<input type="checkbox"/> Redes/Amend	<input type="checkbox"/> Subdivision	
<input type="radio"/> Building Envelopes	<input type="checkbox"/> Redes/Amend	<input type="checkbox"/> Subdivision	<input type="checkbox"/> Development
<input type="radio"/> Traffic Impact Assessment (TIA)	<input type="checkbox"/> Redes/Amend	<input type="checkbox"/> Subdivision	<input type="checkbox"/> Development
<input type="radio"/> Environmental Site Assessment (Phase1 / Phase2)	<input type="checkbox"/> Redes/Amend	<input type="checkbox"/> Subdivision	<input type="checkbox"/> Development
<input type="radio"/> Other: _____	<input type="checkbox"/> Redes/Amend	<input type="checkbox"/> Subdivision	<input type="checkbox"/> Development

ADDITIONAL ROAD WIDENING REQUIRED:

No Caveat Survey Out

Amount _____m Location of Widening Required: N E S W

Other: _____

No Caveat Survey Out

Amount _____m Location of Widening Required: N E S W

Other: _____

See reverse side.....

Brittany Smith

From: Tracy Davidson <tracy.davidson@fortisalberta.com> on behalf of Land Service <landserv@fortisalberta.com>
Sent: March 31, 2026 3:44 PM
To: Brittany Smith
Subject: FW: [CAUTION] Circulation for Development Permit 26D 075, Please reply by April 9, 2026
Attachments: 26D 075_Circ Pkg.pdf

Hello,
Please be advised FortisAlberta Inc. has no concerns regarding this development permit.

Please ensure the applicant knows they must contact 310-WIRE if working within 8 meters of our facilities to arrange for an onsite safety orientation and to make arrangements for any electrical services or visit www.fortisalberta.com.



Thank you,

Tracy Davidson | Land Coordinator

FortisAlberta Inc. | 100 Chippewa Road, Sherwood Park, AB, T8A 4H4 | Direct 780-464-8815

**FORTIS
ALBERTA**



We are FortisAlberta. We deliver the electricity that empowers Albertans to succeed. We keep the power on, not just because it's our job, but because we care about the people we serve. We are reliable, honest and dedicated to our work because our employees, customers and communities matter to us.



ATCO TRANSMISSION_DISTRIBUTION 4902: Circulation for Development Permit 26D 075, Please reply by April 9, 2026

From Newton, Shannon (Contractor) <shannon.newton@atco.com>
Date Fri 4/17/2026 2:28 PM
To FC_Planning <Planning@Foothillscountyab.ca>

ATCO Distribution and ATCO Transmission wish to confirm we have no objection as we have no pipelines in the proposed area.
Thank you for allowing ATCO to review your proposal and provide feedback.

Shan Newton, CONTRACTOR

Administrator, Circulations Team

E: Shannon.newton@atco.com

ATCO Pipelines & Liquids Global Business Unit

From: FC_Planning <Planning@Foothillscountyab.ca>
Sent: Monday, March 9, 2026 8:31 AM
To: Kurtis Dyck <Kurtis.Dyck@FoothillsCountyAB.ca>; Land Service <landserv@fortisalberta.com>; CirculationsGrowthandImprovement <CirculationsGrowthandImprovement@atco.com>; Gas Land Department <land.admin@atco.com>
Cc: Brittany Smith <Brittany.Smith@FoothillsCountyAB.ca>
Subject: Circulation for Development Permit 26D 075, Please reply by April 9, 2026

CAUTION: This email originated outside of ATCO. Do not click links or open attachments unless you trust the sender and know the content is safe. Immediately report suspicious emails using the **Phish Alert Report button**.

Good Morning,
Find attached our circulation for development permit 26D 075. Please review and respond **prior to April 9, 2026**.

Should you have any questions or comments, please direct them to **Brittany Smith** at Brittany.Smith@foothillscountyab.ca .

Regards,

**Foothills County
Planning & Development**

FC_Planning@foothillscountyab.ca

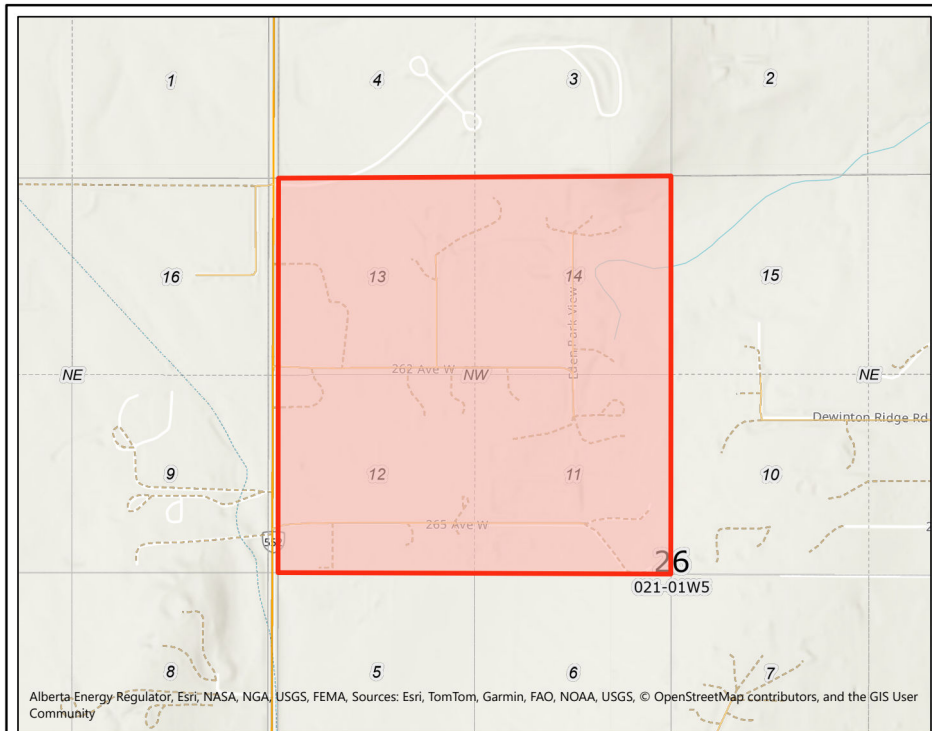

<Layout_Title>		Base Data provided by: Government of Alberta	
		Author: YYY	Print Date: 5/29/2026
Legend <ul style="list-style-type: none"> Abandoned Wells Revised Location Revised Location Pointer Paved Road (20K) <ul style="list-style-type: none"> Primary Divided Primary Undivided 4L Primary Undivided 4R Primary Undivided 2L Primary Undivided 1L Interchange Ramp Interchange Ramp Secondary Divided Secondary Undivided 4L Secondary Undivided 2L Secondary Undivided 1L Gravel Road (20K) <ul style="list-style-type: none"> Primary Undivided 2L Primary Undivided 1L Secondary Undivided 2L Secondary Undivided 1L Railway (20K Large Scale) <ul style="list-style-type: none"> Single Line Double Line Multiple Line Spur Line Abandoned ATS LSD label Roads - Other <ul style="list-style-type: none"> Unimproved Undeclared Truck Trail Winter Ford Winter Crossing Ferry Road Gravel Road (20K) <ul style="list-style-type: none"> Primary Undivided 2L Primary Undivided 1L Secondary Undivided 2L Secondary Undivided 1L Lake/River (20K) <ul style="list-style-type: none"> Lake or River Lake or River Reservoir Koefield Major Canal Oxbow Quarry Dugout Intermittent Lake <ul style="list-style-type: none"> Intermittent Lake Intermittent Oxbow Sandbar / Wetland / <ul style="list-style-type: none"> Sandbar ATS LSD with Road ATS Quarter Section label ATS Quarter Section with ATS Section label (large) ATS Section with Road ATS Township (large scale) Lake Label (20K) River Label (20K) 		<p>The Alberta Energy Regulator (AER) has not verified and makes no representation or warranty as to the accuracy, completeness, or reliability of any information or data in this document or that it will be suitable for any particular purpose or use. The AER is not responsible for any inaccuracies, errors or omissions in the information or data and is not liable for any direct or indirect losses arising out of any use of this information. For additional information about the limitations and restrictions applicable to this document, please refer to the AER Copyright & Disclaimer webpage: <LINK>http://www.aer.ca/copyright-disclaimer</LINK></p>	 Projection and Datum WGS 1984 Web Mercator Auxiliary Sphere Scale 1:14,713

If no wells are listed on-site:

I, Cam Perdonic being the registered
Owner(s) or agent acting on behalf of the registered owner(s)
of Nuvo Renewables
(Legal Description)

Do hereby confirm that I have done my due diligence as required by Alberta Municipal Affairs, the M.D. of Foothills, and the AER by obtaining required information from the 'Abandoned Well Map Viewer" and/or through the AER Information Services, and hereby attach "Schedule A" containing a map of the search area from the viewer and a statement identifying that no abandoned well sites were noted on the above legal description.

Cam Perdonic
Owner/Agent
DATED: this 12 day of 02, 2026.

OR

If wells are listed on-site:

I, _____ being the registered
Owner(s) or agents acting on behalf of the registered owner(s)
of _____
(Legal Description)

Do hereby confirm that I have done my due diligence as required by Alberta Municipal Affairs, the M.D. of Foothills, and the AER, by obtaining required information from the 'Abandoned Well Map Viewer" and/or through the AER Information Services, and hereby attach "Schedule A" containing a list and map identifying the locations of abandoned wells within the search area, including the surface coordinates, written confirmation that I have contacted the licensee for each well and that the exact location of each well has been confirmed, a sketch of the proposed development incorporating the necessary setback area for each well, and a statement confirming that abandoned wells will be temporarily marked with on-site identification to prevent contact during construction, if the development will result in construction activity within the setback area.

Owner/Agent
DATED: this _____ day of _____, 20_____.

This form shall accompany all applications for Land use, Subdivisions, Development Permits and Building Permits.

NW 26-21-1 W5M; Plan 0110200, Block 3, Lot 7

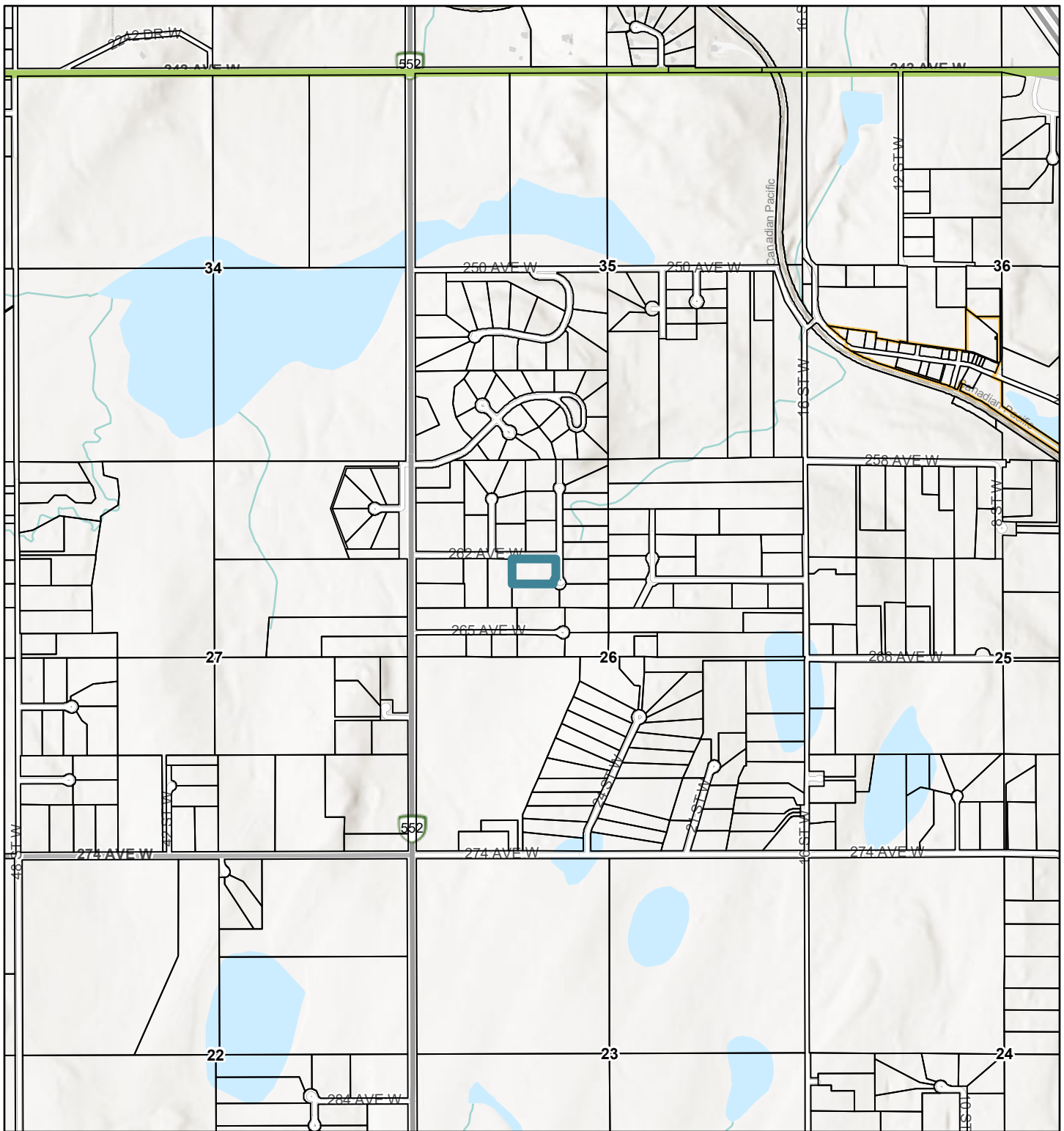

2026-03-04, 3:45:22 p.m.

- Parcels
- Settlement
 - Hamlet
 - Townships

World_Hillshade

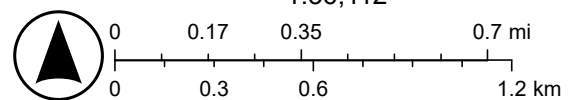

Esri, NASA, NGA, USGS, FEMA

NW 26-21-1 W5M; Plan 0110200, Block 3, Lot 7



2026-03-04, 3:44:06 p.m.

 Parcels

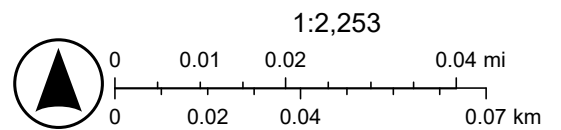



FOOTHILLS COUNTY

309 Macleod Trail, Box 5605

High River, Alberta T1V 1M7

Phone: 403-652-2341

Fax: 403-652-7880

www.FoothillsCountyAB.ca

planning@foothillscountyab.ca

May 6, 2026

Nuvo Renewables Inc.
2875 107 Ave SE
Calgary, AB T2Z 4S8

Dear Sir/Madam:

**Re: Notice of Decision Re: Development Permit 26D 075
Ptn: NW 26-21-1 W5M; Plan 0110200, Block 3, Lot 7
Ground Mount Solar Power System, Private**

The above-noted development permit application has been approved subject to conditions (copy attached) and subject to a 21-day appeal period. The Development Permit may be signed and issued upon completion of the 21-day appeal period; should no appeals be received, and completion of all Pre-Release Conditions (if any).

The County will advertise the approval of this development permit application in two issues of the Western Wheel and circulate to area landowners (according to County records at this time) within the subject quarter section and for one half mile surrounding the subject property. Notices for Development Permit Decisions are also posted on the County website, www.foothillscountyab.ca.

Pursuant to Section 685(2) of the Municipal Government Act, a person affected by this decision has a right of appeal. Notices of Appeal, including payment of the appeal fee are to be received **no later than May 28, 2026**. Notices of Appeal received after the 21-day notification period will be invalid. If you choose to submit an appeal, please use the enclosed '**Notice of Development Appeal**' form. We will notify you if we receive appeals from other persons.

Should you have any questions, concerns, or require clarification on the appeal process, please contact the undersigned.

**NOTE: APPEAL SUBMISSION REQUIREMENTS ARE OUTLINED ON THE ENCLOSED
'NOTICE OF DEVELOPMENT APPEAL' FORM**

Yours truly,
FOOTHILLS COUNTY

Brittany Smith
Development Officer
Brittany.Smith@foothillscountyab.ca
(403) 603-6257

BS/as
Encl.

cc. Landowners – John & Catherine Bye